

FS-5900C

Contents

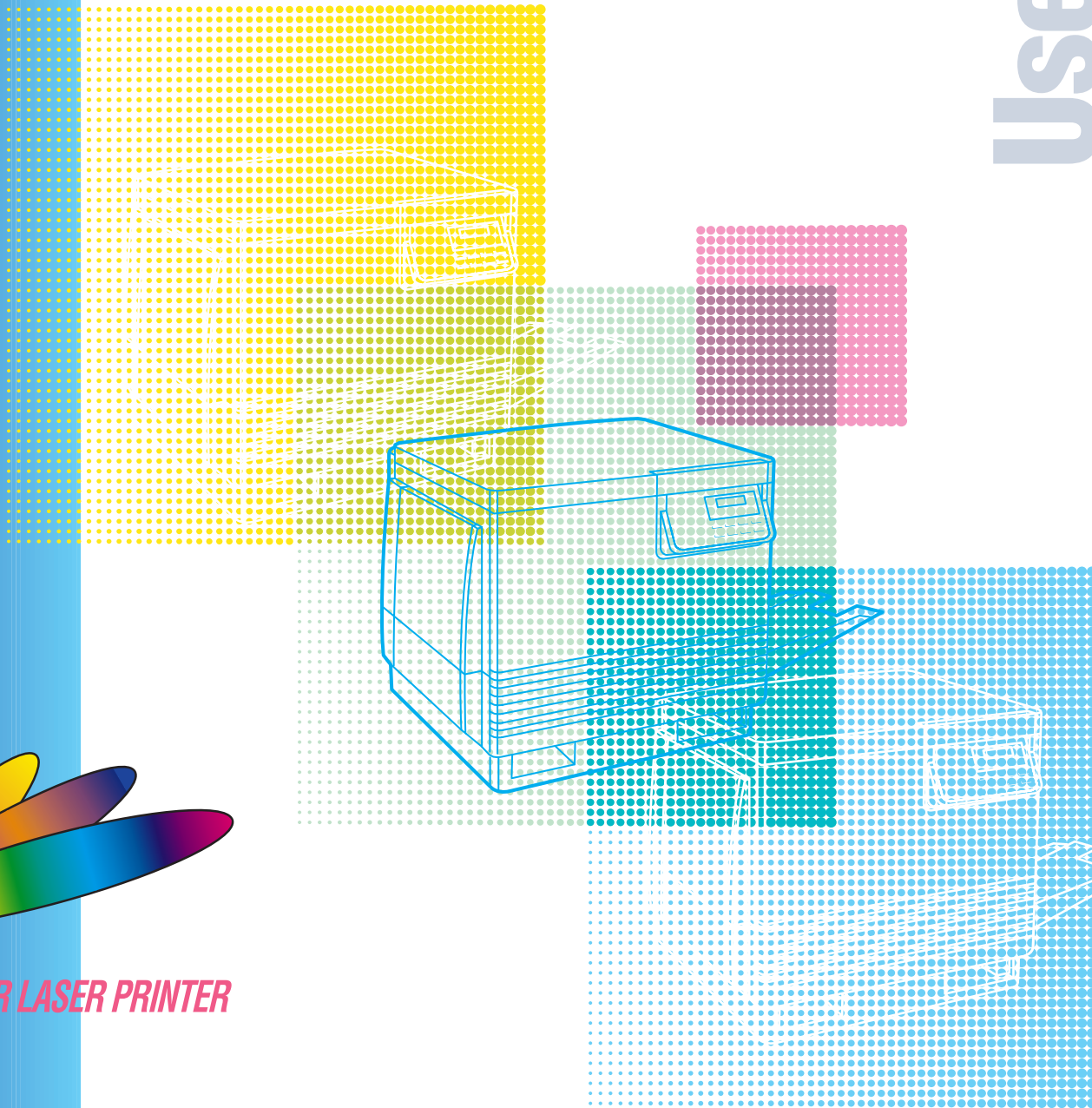

COLOUR LASER PRINTER

Thank you for purchasing the Kyocera FS-5900C Colour Laser Printer.

Notice

NO LIABILITY IS ASSUMED FOR ANY DAMAGE CAUSED BY IMPROPER INSTALLATION.

The information in this manual is subject to change without notification. Additional pages may be inserted in future editions. The user is asked to excuse any technical inaccuracies or typographical errors in the present edition.

SOFTWARE USED WITH THIS PRINTER MUST SUPPORT THE PRINTER'S NATIVE MODE OR ONE OF ITS EMULATION MODES. The printer is factory set to emulate the PCL 5C. The emulation mode can be changed by following the procedures described in *Using the Printer*.

No responsibility is assumed if accidents occur while the user is following the instructions in this manual. No responsibility is assumed for defects in the printer's firmware (contents of its read-only memory).

This manual, any copyrightable subject matter sold or provided with or in connection with the sale of the printer, are protected by copyright. All rights are reserved. Copying or other reproduction of all or part of this manual, any copyrightable subject matter without the prior written consent of the copyright holder is prohibited. Any copies made of all or part of this manual, any copyrightable subject must contain the same copyright notice as the material from which the copying is done.

© Copyright 1999 by Kyocera Corporation and KYUSHU MATSUSHITA ELETRIC CO., LTD. All rights reserved. (Revision 1.1. April 1999)

Regarding Tradenames

KPDL is a trademark of Kyocera Corporation.

HP Colour LaserJet 5 is a product of Hewlett-Packard Company. Hewlett-Packard, PCL, and PJI are registered trademarks of Hewlett-Packard Company. Centronics is a trade name of Centronics Data Computer Corp. Microsoft and Windows are registered trademarks of Microsoft Corporation in the United States and/or other countries. Pentium is a registered trademark of Intel Corporation. PostScript is a registered trademark of Adobe Systems Incorporated. Apple and Macintosh are trademarks of Apple Computer, Inc. registered in the U.S. and other countries. Adobe and Acrobat are trademarks of Adobe Systems Incorporated which may be registered in certain jurisdictions. All other trademarks are the property of their respective owners.

Typeface Trademark Acknowledgement

All resident fonts in this printer are licensed from Bitstream Inc., Cambridge, Massachusetts, U.S.A.

Dutch801, Swiss742, Incised901, ZapfCalligraphic801, ZapfHumanist601, OriginalGaramond, and Chianti are trademarks of Bitstream Inc.

Century Schoolbook, Stymie, and Cooper-Black are trademarks of Kingsley-ATF Type Corporation.

ITC AvantGarde, ITC Benguiat, ITC Bookman, ITC Souvenir, ITC ZapfChancery, and ITC ZapfDingbats are registered trademarks of International Type-face Corporation.

Revue is a trademark of Esselte Pendaflex Corporation in the U.S., Letraset Canada Ltd. in Canada, and Esselte Letraset Ltd. elsewhere.

Bitstream Sublicense Agreement

FONTWARE/TrueDoc developed by BITSTREAM INC. is provided as part of this Printer by KYOCERA CORPORATION under license. KYOCERA, as a Licensee of BITSTREAM, grants you, the Sublicensee, non-exclusive right to use FONTWARE/TrueDoc installed in this Printer, if you agree to and at all times comply with the following items:

1. Ownership

As the Sublicensee, you own the Printer in which FONTWARE/TrueDoc is originally installed, but BITSTREAM retains title to and ownership in the software program of FONTWARE/TrueDoc. The Sublicense is not a sale of the original software program of FONTWARE/TrueDoc or any portion or copy of it.

2. Copy Restrictions

FONTWARE/TrueDoc is copyrighted. Unauthorized copying of FONTWARE/TrueDoc even if modified, merged, or included with other software, is expressly forbidden. You may be held legally responsible for any copyright infringement.

3. Unauthorized Use

FONTWARE/TrueDoc may not be removed, disclosed and transferred to any third party for any length of time without the prior written consent of KYOCERA or BITSTREAM. Also, you may not modify, adapt, translate, reverse engineer, decompile, or create derivative works based on FONTWARE/TrueDoc.

4. Term

This agreement should remain in full force and effect forever thereby allowing the Sublicensee to use the FONTWARE/TrueDoc forever unless the Sublicensee violates the terms of paragraphs 2. or 3. above. In the event of such violation, this agreement will terminate automatically without notice from KYOCERA. Upon termination, you should destroy FONTWARE/TrueDoc and all copies of them, in part and in whole, including modified copies, if any.

Important note on the interface connectors

Be sure to turn off printer power before connecting or disconnecting an interface cable* to the printer. For protection against static discharge which may be applied to the printer's internal electronics through the interface connector(s), keep any interface connector which is not in use capped using the protective cap supplied.

* **A shielded interface cable must be used.**

Ozone concentration

The printer generates ozone gas (O₃) which may concentrate in the place of installation and cause an unpleasant smell. To minimize concentration of ozone gas to less than 0.1 ppm, we recommend you not to install the printer in a confined area where ventilation is blocked.

IMPORTANT SAFEGUARDS

1. Read all of these instructions and save these instructions for later use.
2. Unplug this product from the wall outlet before cleaning.
3. Do not use this product near water.
4. Do not place this product on an unstable cart, stand, or table. The product may fall, causing serious damage to the product.
5. Slots and openings in the cabinet and the back are provided for ventilation to ensure reliable operation of the product and to protect it from overheating, these openings must not be blocked or covered. The openings should never be blocked by placing the product on a bed, sofa, rug, or other similar surface. This product should never be placed near or over a radiator or heat register. This product should not be placed in a built-in installation unless proper ventilation is provided.
6. This product is equipped with a 3-wire grounding type plug, a plug having a third (grounding) pin. This plug will only fit into a grounding-type power outlet. This is a safety feature. If you are unable to insert the plug into the outlet, contact your electrician to replace your obsolete outlet. Do not defeat the purpose of the grounding-type plug.
7. Do not allow anything to rest on the power cord. Do not locate this product where persons will walk on the cord.
8. If an extension cord is used with this product, make sure that the total of the ampere ratings on the products plugged into the extension cord do not exceed the extension cord ampere rating.
9. Never push objects of any kind into this product through cabinet slots as they may touch dangerous voltage points or short out parts that could result in a risk of fire or electric shock. Never spill liquid of any kind on the product.
10. Except as explained elsewhere in User's Manual, do not attempt to service this product yourself. Removing covers may expose you to dangerous voltage points or other risks. Refer all servicing in those compartments to service personnel.
11. Unplug this product from the wall outlet and refer servicing to qualified service personnel under the following conditions:
 - A – When the power cord or plug is damaged or frayed.
 - B – If liquid has been spilled into the product.
 - C – If the product has been exposed to rain or water.
 - D – If the product does not operate normally when the operating instructions are followed. Adjust only those controls that are covered by the operating instructions since improper adjustment of other controls may result in damage and will often require extensive work by a qualified technician to restore the product to normal operation.
 - E – If the product has been dropped or the cabinet has been damaged.

CE Marking Directive

according to Council Directive 89/336/EEC and 73/23/EEC

Manufacturer's name: Kyocera Corporation, Printer Division
Manufacturer's address: 2-14-9 Tamagawadai, Setagaya Ward, Tokyo 158-8610, Japan

declares that the product

Product name: Colour Laser Printer
Model number: FS-5900C (as tested with enhancement optional units: PF-81, DU-81 and HD-2C)

conforms to the following product specifications.

EN 55 022:1994 (Class B)
EN 61 000-3-2:1995
EN 61 000-3-3:1995

EN 50 082-1:1997

EN 60 950:1992+A1+A2+A3+A4
EN 60 825-1:1994

The manufacturer and its merchandising companies retain the following technical documentation in anticipation of the inspection that may be conducted by the authorities concerned.

User's instruction that conforms to the applicable specifications
Technical drawings
Descriptions of the procedures that guarantee the conformity
Other technical information

KYOCERA ELECTRONICS EUROPE GmbH
Mollsfeld 12
40670 Meerbusch, Germany
Phone: +49 21 59 918 0
Fax: +49 21 59 918 100

ISO 7779

Maschinenlärminformationsverordnung 3. GSGV, 18.01.1991: Der höchste Schalldruckpegel beträgt 53 dB(A) oder weniger gemäß ISO 7779.

Declaration of Conformity (Australia)

Manufacturer's name: Kyocera Corporation, Printer Division
Manufacturer's address: 2-14-9 Tamagawadai, Setagaya Ward, Tokyo 158-8610, Japan

declares that the product

Product name: Colour Laser Printer
Model number: FS-5900C (tested with PF-81, DU-81 and the HD-2C)

Conforms to the following product specifications.

AS/NZS 3548: 1995 (EN 55 022:1994 Class B)
IEC60950 (EN 60 950:1992+A1+A2+A3+A4)
IEC60825 (EN 60 825-1:1994)

Description of device:

The model FS-5900C utilizes plain paper, laser, dry toner etc. The printer can be equipped with several enhancement optional unit[s] such as the harddisk unit HD-2C.

The manufacturer and its merchandising companies retain the following technical documentation in anticipation of the inspection that may be conducted by the authorities concerned.

- User's instruction that conforms to the applicable specifications
- Technical drawings
- Descriptions of the procedures that guarantee the conformity
- Other technical information

KYOCERA ELECTRONICS AUSTRALIA PTY., LTD

Unit 6 112 Talavera Road North Ryde, NSW 2113, Australia
Phone: +61-2-9888-9999
Fax: +61-2-9888-9588

Disclaimer

We shall have no liability or responsibility to customers or any other person or entity with respect to any liability, loss or damage caused or alleged to be caused directly or indirectly by equipment sold or furnished by us, including but not limited to, any interruption of service, loss of business or anticipatory profits, or consequential damages resulting from the use or operation of the equipment or software.

ENERGY STARSM



As an ENERGY STAR Partner, Kyocera Corporation has determined that this product meets the ENERGY STAR guidelines for energy efficiency.

The basic objective of the ENERGY STAR Program is to reduce environmental pollution by encouraging the manufacture and sale of equipment that uses energy more efficiently.

This printer is equipped with a sleep timer function that conforms with the standards of the ENERGY STAR Program. This function makes it possible to reduce the amount of electrical power consumed by the printer. For maximum power savings, turn off the printer's power supply when not using the printer for extended periods of time.

Initial settings of the sleep timer function and power saved using the sleep timer function (Values in brackets are ENERGY STAR program guide lines.):

Initial sleep mode setting	Power consumption during sleep mode
60 minutes (60 minutes)	45 W (45 W)

Chapter 1

Before You Start

Cautions	1
Features	3
System Requirements	4
PC	4
Interface	4
Minimum Space Requirements	5
Power Source	5
Unpacking	6
Part Names	7
Control Panel Overview	8

Chapter 2

Setup

Setting Up the Printer	12
Preparing the Imaging Unit	12
Setting Up the Output Tray	13
Installing the Toner Developers	14
Loading Media	16
Loading Paper or Transparencies in the Media Cassette	16
Loading Media in the Multi-purpose Tray	19
Connecting the Printer to a Computer	23
Using a Parallel Interface Cable	24
Connecting the Serial Interface	25
Installing the Hard Disk Option	25
Power On	25
Printing a Status Page From the Printer Control Panel	26
Installing the Driver Software	27
Installing the Printer Driver for Windows 3.1	27
Installing the Printer Driver for Windows 95/ Windows 98	28
Setting the Colour Density	30

Chapter 3

Using the Printer

Mode Selection	34
Navigating through the menus	37
Outline for Menus	38
Other menus (Others)	47
RAM DISK	51
Virtual Mail Box (VMB)	52
Memory Cards	57
Setting the Sleep Timer	62
Resource Protection	62

Contents

Chapter 4

Care and Maintenance

Cleaning	64
User Replaceable Components	69
Clearing a Jam	71
Troubleshooting	85
Error Messages	93
Printer Panel Message	93
Repacking	101

Appendix

Specifications	110
Printer	110
Media	111
Margins and Print Area	112
Software	115
Bi-directional Parallel Interface	116

General

Warning

To prevent fire or shock hazard, do not expose this product to rain or any type of moisture.

Caution

Do not open covers and do not attempt to repair the unit yourself. Refer servicing to qualified personnel.

Power Source

Warning

- The power source voltage of this unit is listed on the nameplate. Only plug the unit into an outlet with the proper voltage.
- When you operate this equipment, the outlet should be near the equipment and accessible.
- To ensure safe operation the AC cord supplied must be inserted into standard three-prong AC outlet which is effectively grounded (earthed) through the normal wiring.
- The fact that the equipment operates satisfactorily does not imply that the power point is grounded (earthed) and that the installation is completely safe. For your safety, if in any doubt about the effective grounding (earthing) of the power point, consult a qualified electrician.
- If the plug cannot be inserted into the AC outlet, contact a licensed electrician to replace the outlet with a properly grounded (earthed) one. Do not defeat the purpose of the grounding (earthing) plug (e.g. using a conversion plug).

Laser Safety

Caution

This printer utilizes a laser. Use of controls or adjustments or performance of procedures other than those specified herein may result in hazardous radiation exposure.

Ozone Release

Warning

Make sure that the printer is installed in a well ventilated room so as not to increase density of ozone in the air. Since ozone is heavier than air, it is recommended that air at floor level be ventilated.

For Your Safety

Moving the Unit

The printer weighs approximately 51 kg (112 lbs.). It must be handled by two people. Turn the power off and remove the power cord when handling the unit.

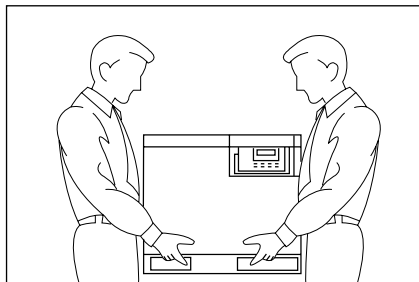

Caution Labels

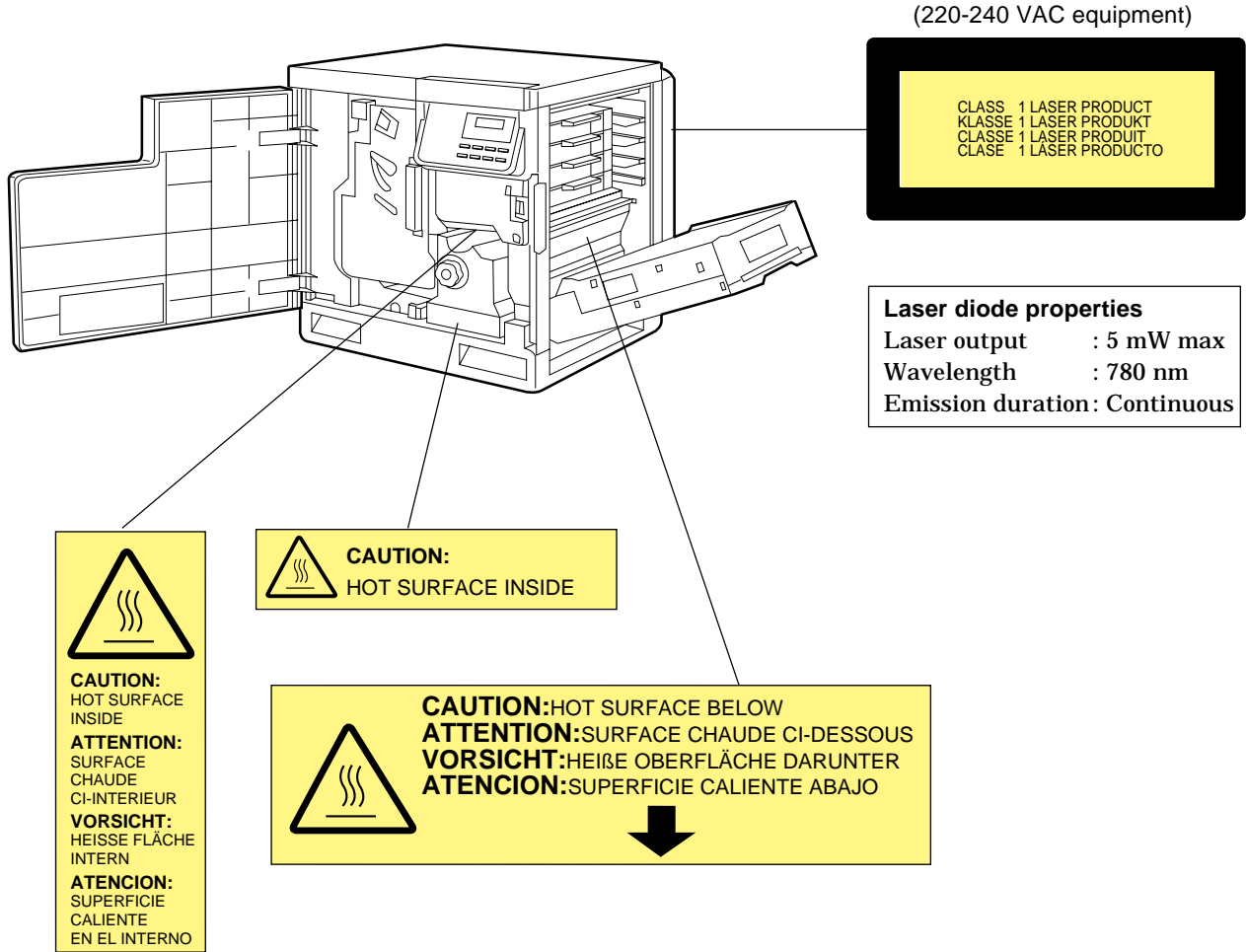



For Your Safety

FOR USERS IN THE UK

IMPORTANT:

FOR YOUR SAFETY PLEASE READ THE FOLLOWING TEXT CAREFULLY

This printer is supplied with a moulded three pin mains plug each for your safety and convenience. A 13 amp fuse is fitted in this plug. Should the fuse need to be replaced please ensure that the replacement fuse has a rating of 13 amps and that it is approved by ASTA or BSI to BS 1362.

Check for the ASTA mark  or the BSI mark  on the body of the fuse.

If the plug contains a removable fuse cover you must ensure that it is refitted when the fuse is replaced. If you lose the fuse cover the plug must not be used until a replacement cover is obtained. A replacement fuse cover can be purchased from your local dealer.

IF THE FITTED MOULDED PLUG IS UNSUITABLE FOR THE SOCKET OUTLET IN YOUR HOME THEN THE FUSE SHOULD BE REMOVED AND THE PLUG CUT OFF AND DISPOSED OF SAFELY. THERE IS A DANGER OF SEVERE ELECTRICAL SHOCK IF THE CUT OFF PLUG IS INSERTED INTO ANY 13 AMP SOCKET.

If a new plug is to be fitted please observe the wiring code as shown below. If in any doubt please consult a qualified electrician.

WARNING: THIS APPLIANCE MUST BE EARTHED.

IMPORTANT: The wires in this mains lead are coloured in accordance with the following code.

Green-and-Yellow: Earth Blue: Neutral Brown: Live

As the colours of the wire in the mains lead of this appliance may not correspond with the coloured markings identifying the terminals in your plug, proceed as follows.

The wire which is coloured GREEN-AND-YELLOW must be connected to the terminal in the plug which

is marked with the letter E or by the Earth symbol , or coloured GREEN or GREEN-AND-YELLOW.

The wire which is coloured BLUE must be connected to the terminal in the plug which is marked with the letter N or coloured BLACK.

The wire which is coloured BROWN must be connected to the terminal in the plug which is marked with the letter L or coloured RED.

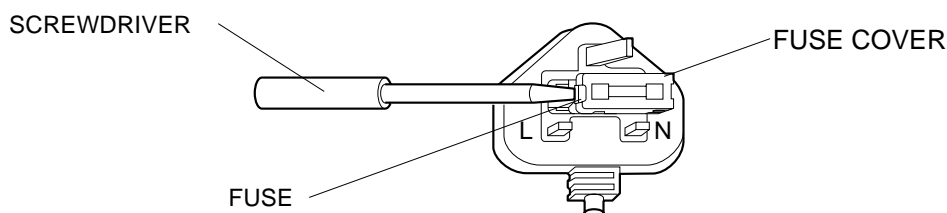

How to replace the fuse: Open the fuse compartment with a screwdriver and replace the fuse.



Before You Start

Cautions

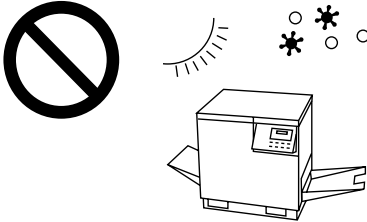
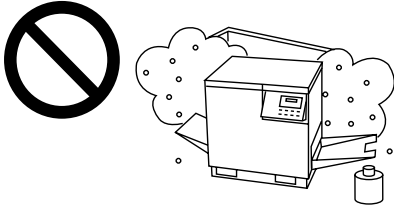
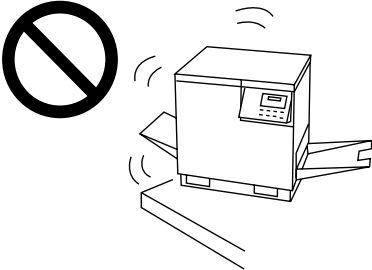
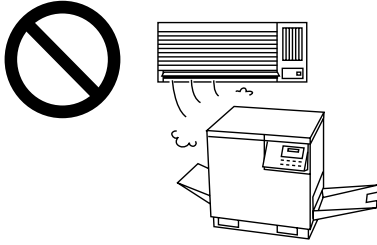
To avoid machine malfunction, do not use the equipment under the following conditions:

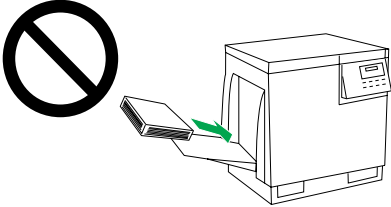
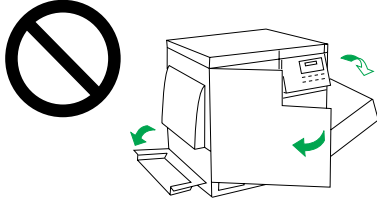
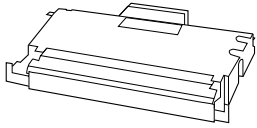
 <ul style="list-style-type: none">• Direct exposure to sunlight• Extremely high or low temperature [temperature range: 10°C to 32.5°C (50°F to 90.5°F)]• Extremely high or low humidity (humidity range: 20% to 80% RH)• Condensation due to rapid change of temperature	 <ul style="list-style-type: none">• Areas of poor ventilation• Areas of high dust or chemical fume concentration (solvent etc.)	
 <ul style="list-style-type: none">• Unstable or unlevel surfaces	 <ul style="list-style-type: none">• Directly in front of air conditioning vents	 <ul style="list-style-type: none">• Liquids near the equipment
 <ul style="list-style-type: none">• Too much media which exceeds the limit mark on the guide of the tray.	 <ul style="list-style-type: none">• Front/right/left covers opened while the printer is operating. It may cause a media jam.	 <p>Genuine or Original</p> <ul style="list-style-type: none">• We strongly recommend to use only the original Kyocera toner developer. Use of Kyocera toner developer assures the intended long term reliability of the printer.

Before You Start

■ CD-ROM

To prevent the CD-ROM from accidental damages:

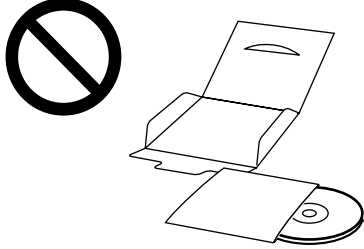
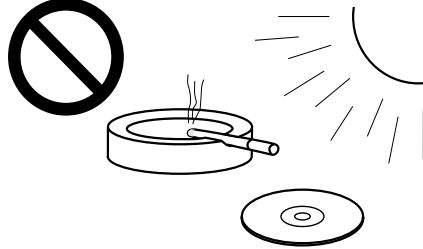
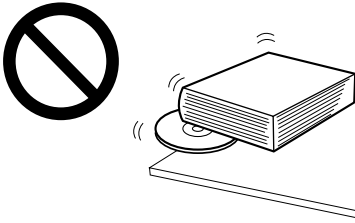
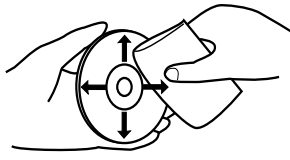
 <ul style="list-style-type: none">• Do not touch or write on the surface of the disc.	 <ul style="list-style-type: none">• Do not leave the disc out of the protective case.	 <ul style="list-style-type: none">• Do not leave the disc in direct sunlight or near heat sources.
 <ul style="list-style-type: none">• Do not place heavy objects on the disc.	 <ul style="list-style-type: none">• To clean the disc, hold the disc by its edges and wipe it from the centre to the edges with a dry, soft cloth.	

■ Static Electricity Damage

To prevent static electricity damage to any of the following components, touch a grounded metal surface, such as the printer's bare metal frame prior to touching the component.

- The interface connectors: Parallel and optional network card
- Electrical components, connectors inside the printer and any components on the optional boards (RAM expansion board, network interface board, etc.)
- The connector pins on the optional paper feeder for the printer

■ Interface Cable

Always use a shielded interface cable. Use of an unshielded cable can result in radio interference with data.

■ Waste Disposal Method

Waste material may be dumped or incinerated under conditions which meet the applicable environmental regulations.

Features

The FS-5900C Colour Laser Printer provides fast, high-quality colour printing on plain paper, plus the ease of operation and high performance you expect from a laser printer.

Some of its features include:

■ **High quality**

Resolution

Maximum 1200 dpi*

(*KPD L emulation only)

■ **High speed**

For printing of multiple copies on various sizes of paper

Full-colour mode: Maximum 4 ppm (pages per minute)

Monochrome mode: Maximum 16 ppm

■ **Easy operation**

Printer driver

Easily prints full-colour documents.

Before You Start

System Requirements

PC

To operate the FS-5900C effectively, refer to the following:

CPU:	More than Pentium (133 MHz or faster CPU is recommended.)
Operating System:	Windows 3.1 ^{*1} / Windows 95 ^{*2} / Windows 98 ^{*3} Windows NT ^{*4}
RAM:	16 MB or more (More than 32 MB is recommended.)
Free disk space:	100 MB or more
Virtual memory:	16 MB or more (More than 32 MB is recommended.)
Display:	Video card that can display more than 256 colours. (32,000 colour recommended.)
Drive:	CD-ROM drive

^{*1} Microsoft® Windows® operating system Version 3.1 (hereafter Windows 3.1)

^{*2} Microsoft® Windows® 95 operating system (hereafter Windows 95)

^{*3} Microsoft® Windows® 98 operating system (hereafter Windows 98)

^{*4} Microsoft® Windows® NT 3.51/4.0 operating system (hereafter Windows NT)

Interface

■ Parallel interface requirement

Interface	Based on the IEEE1284 standard (An ECP compatible parallel port is recommended for Windows 95. To turn on the ECP mode, use the computer's BIOS setup. Refer to the computer's manual for details.)
------------------	---

■ Network interface requirements

	Manufacturer	Model	Applicable country
Ethernet	HBM	HB-7SNMP	Available in UK and France
	DPI	EcoLAN 2000E	Available in USA and Japan
	SEH	IC59-ETHER-KYO2	Other countries
Token Ring	SEH	IC69-Token-KYO2	All countries
	HBM	HB-8	Available in UK and France

See your nearest dealer of the manufacturer for availability.

Minimum Space Requirements

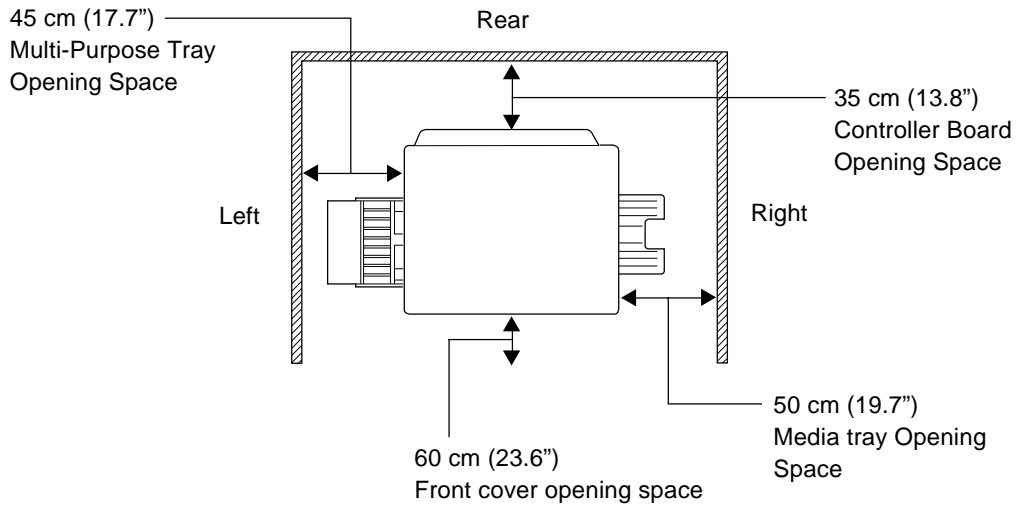

Power Source

- The voltage level of the power source must not vary more than $\pm 10\%$ from the voltage level marked on the nameplate (located on the back of the unit).
- Do not use an extension cord.
- Do not use a line conditioner, transient suppressor or surge protector as it may cause a machine error.

Before You Start

Unpacking

Make sure that all of the items shown below were provided and have not been damaged. Report damage or shortages to the reseller from which the unit was purchased.

Note:

Save the original carton and packing materials for future shipping and transporting of the unit. They have been specifically designed to protect the equipment during shipment.

1. Printer (Colour imaging unit, Fuser kit, Paper cassette and Output tray are included.)
2. Toner developers (black, cyan, magenta, and yellow)
3. Power cord
4. CD-ROM (Manuals, drivers, utilities)
5. Colour Calibration Reference card

1

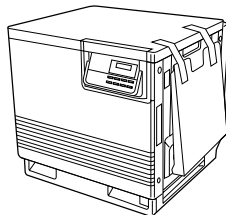

2

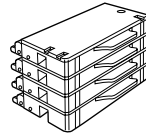

3



4

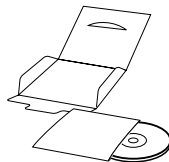

5

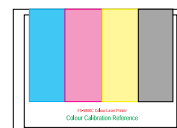

Part Names

■ Front side view

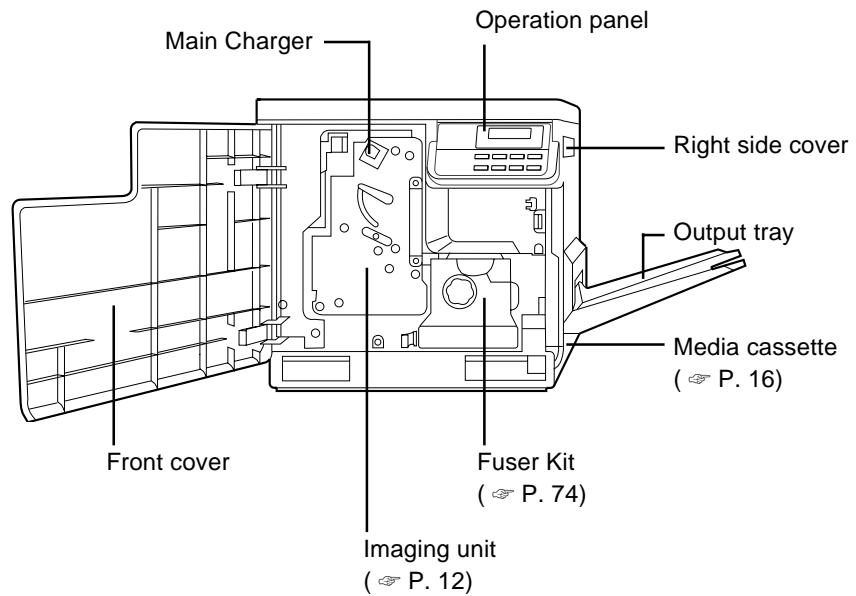

■ Rear side view

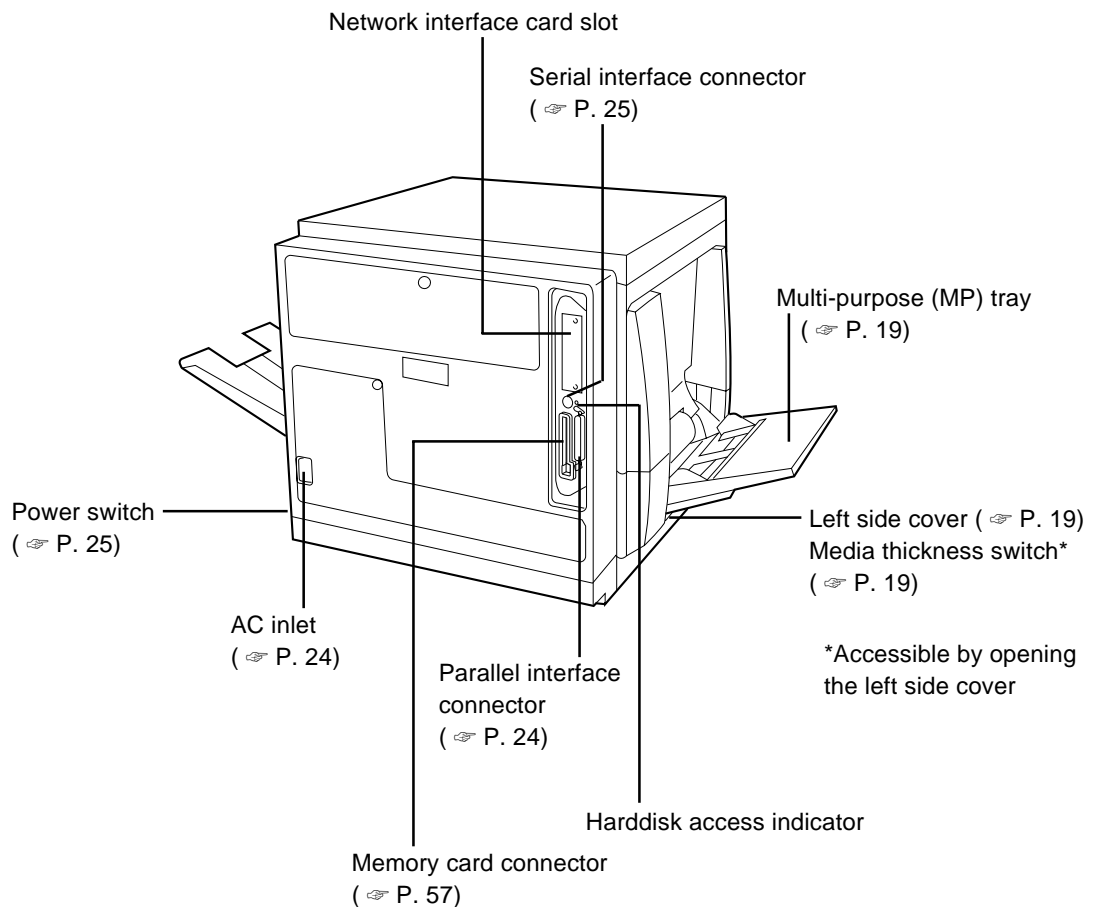

Before You Start

Control Panel Overview

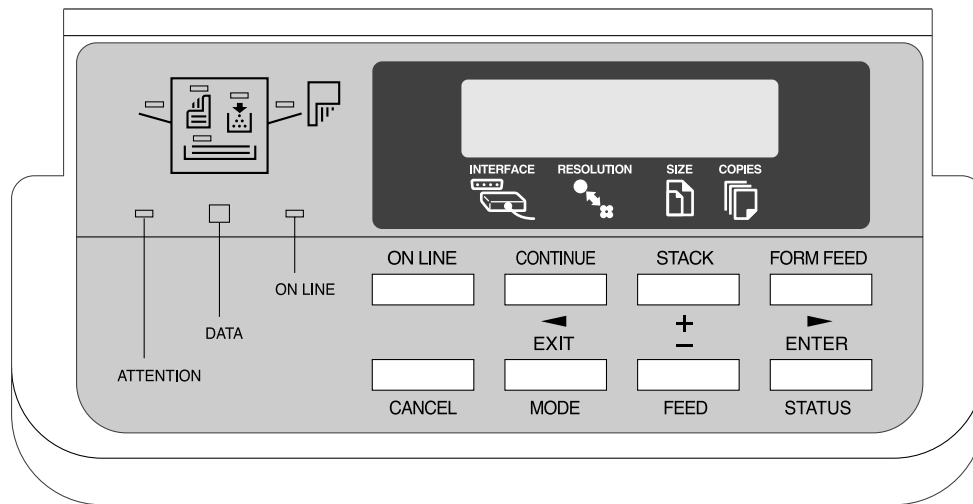

Message Display

The message display displays the printer's operational mode. Messages which are displayed and their meanings are given in the table below.

Message	Meaning
Self test	The printer is self-testing after power-up and is not ready to print.
Please wait	The printer is warming up and is not ready to print.
Ready	The printer is ready to print.
Processing	The printer is processing print data or in the middle of printing.
Waiting	The last page remains unprinted. The printer waits awhile and eventually generates a form feed allowing the last page to be printed. (The length of time depends on the form feed timeout setting.) The printing will begin immediately when the Form Feed key is pressed. If a memory card is being used this can indicate the printer is waiting for data to be written (☞ P. 57).
FormFeed TimeOut	An automatic form feed has been generated.



Interface Indicator

The interface indicator indicates the interface over which data is currently being received or was last received. The current interface is indicated by one of the following messages:

Display	Description
PAR	Parallel interface
SER	Serial interface
OPT	Optional interface (if a network interface card is installed)

Note:

The display will blink while the printer is receiving data and continue blinking until the interface is released, even after data transmission is finished.



Resolution Indicator

This shows the current printing resolution in either 1200 or 600 dpi (dots-per-inch).



Paper Size Indicator

This indicator indicates the paper size of the cassette currently selected. The following abbreviations are used to indicate the paper sizes:

Indicator	Paper Size
A4	ISO A4 (21 × 29.7 cm)
EX *	Executive (7- ¹ / ₄ × 10- ¹ / ₂ inches)
B5 *	JIS B5 (18.2 × 25.7 cm)
LT	Letter (8- ¹ / ₂ × 11 inches)
LG	Legal (8- ¹ / ₂ × 14 inches)
b5 *	ISO B5 (17.6 × 25.0 cm)

* These paper sizes can only be used in the multi-purpose (MP) tray.











Copy Indicator

This indicator indicates the number of copies to print from 001 to 999. This number is reduced as printing proceeds.









Before You Start

Symbolic Indicator

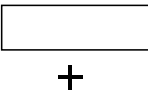
This printer icon includes the indicators which show the following information regarding the printer's paper and toner status.

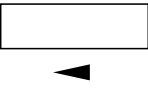
Name	Description
<p>Face-down indicator</p> 	<p>Indicates when printed pages are delivered to the output tray in the face-down stack (correct order). The pages are delivered in the reverse order when this indicator is not lit. If flashing, it indicates that paper is jammed on the output tray.</p>
<p>Toner indicator</p> 	<p>Indicates the status of toner supply in either colour of cyan, magenta, yellow, or black. The toner supply is normal when this indicator is off. If flashing, the toner supply is dwindling. If this is lit, it indicates that the printer is out of toner and not operative until the appropriate toner cartridge is replaced (☞ P. 69).</p>
<p>Cassette feed indicator</p> 	<p>Indicates paper is being fed from the media cassette. When flashing, it indicates that there is no media in the cassette or that media is jammed in the media cassette.</p>
<p>Multi-purpose feed indicator</p> 	<p>Indicates when media is fed from the multi-purpose feed tray. If this is flashing, it indicates that there is no media in the tray or that media is jammed on the multi-purpose tray.</p>
<p>Duplex Indicator</p> 	<p>Indicates when media is being fed from the duplex unit. It flashes when there is no media in the duplex unit, or when the media is jammed in the duplex unit.</p>
<p>ON LINE indicator</p>  <p style="text-align: center;">ON LINE</p>	<p>When lit, it indicates that the printer is on-line (The printer prints received data). When this is off, the printer is offline (The printer stores but does not print received data).</p>
<p>DATA indicator</p>  <p style="text-align: center;">DATA</p>	<p>Flashes when data is arriving at the printer's interface. When lit continuously, it indicates that data is being processed for printing (or that data is being written to the memory card).</p>
<p>ATTENTION indicator</p>  <p style="text-align: center;">ATTENTION</p>	<p>Flashes when the printer needs maintenance (☞ P. 69). When lit continuously, it indicates that the printer cannot print due to an error.</p>

Control Keys

Key	Function
ON LINE ON LINE 	This key toggles the printer on-line and off-line.
CANCEL  CANCEL	This key cancels the data processed in the printer during printing. When the printer is in a mode selection sequence (See MODE key below), pressing this key abandons mode selection in course.
STACK/+ STACK 	<ul style="list-style-type: none"> This key selects whether to output media face-down (printed side down) or face-up (printed side up). During a mode selection sequence, this key is used to select menus and change setting values.
FEED/- -  FEED	<ul style="list-style-type: none"> This key selects the paper feed cassette or multi-purpose tray as the paper source. It can also select an optional feeder if one is installed. Select the alternative paper source when Use alternative? is displayed. During a mode selection sequence, this key is used to select menus and change setting values.
CONTINUE/◀ CONTINUE 	<ul style="list-style-type: none"> In normal operating mode, this key forcibly cancels errors and resumes printing when printing is halted due to errors such as memory overflow. This key functions as the ◀ key during a mode selection sequence: It moves the selection upward in the menu hierarchy or moves the cursor left.
EXIT/MODE EXIT  MODE	This key is used to start and end a mode selection sequence. (☞ P. 34)
FORM FEED/▶ FORM FEED 	<ul style="list-style-type: none"> In normal operating mode, this key is used to forcibly form-feed when a print timeout occurs. This key functions as the ▶ key during a mode selection sequence: It moves the selection downward in the menu hierarchy or moves the cursor right.
ENTER/STATUS ENTER  STATUS	<ul style="list-style-type: none"> During a mode selection sequence, this key confirms the setting made in the mode selection. This key determines the paper source while Use alternative? is being displayed. (☞ P. 94) In normal operating mode, this key prints a status page.

Notes

- Menus set using these keys are enabled only for the interface currently indicated on the message display.
- Settings made from the control panel may be automatically switched to different settings by application software being used.

Setting Up the Printer

Preparing the Imaging Unit

- 1 Open the front cover.

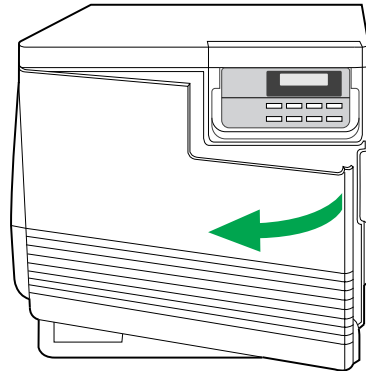

- 2 Turn the upper green lever clockwise until it stops and the arrows are aligned. (This tightens the internal belts, ensuring the unit is ready for printing.)

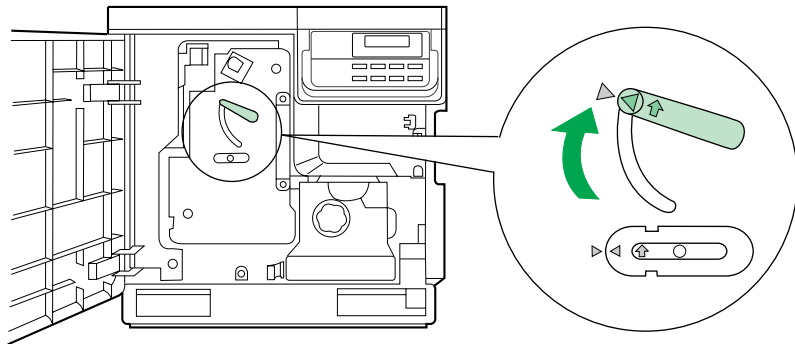

- 3 Close the front cover.

Setting Up the Output Tray

- 1** Remove the adhesive tape that holds the output tray against the printer.

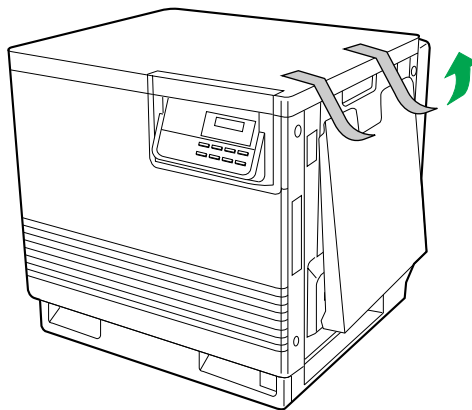

- 2** Lower the tray to the operating position.

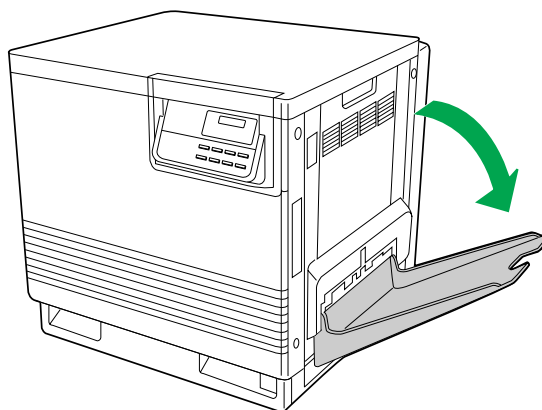

Installing the Toner Developers

Note:

The toner developers that are shipped with the printer are starter developers. They are installed in exactly the same manner as the optional developers; the only difference is that the starter developers have less toner. (The page life expectancy is 5000 pages for colour and 6000 pages for black, both based on a 5% image area.)

1 Remove the packaging from the toner developer.

2 Remove the shipping cover from the developer.

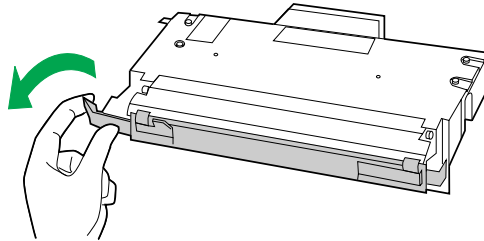

Caution:

To avoid possible toner spillage, do not tilt developer.

Note:

Save all packing material for shipping purpose.

3 Open the right side cover.

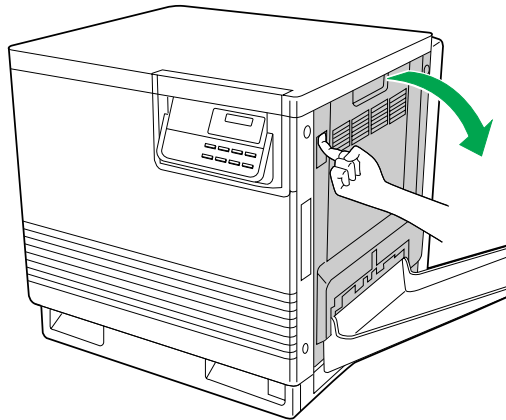

4 Insert the toner developer in the appropriately labelled slot.

From top to bottom, the order of the colour toner developers is BLACK, CYAN, MAGENTA, YELLOW.

Caution:

Excessive exposure to light will damage the imaging unit; do not leave the right side door open for more than 1 minute. Close the right side door after replacing each individual toner developer unit.

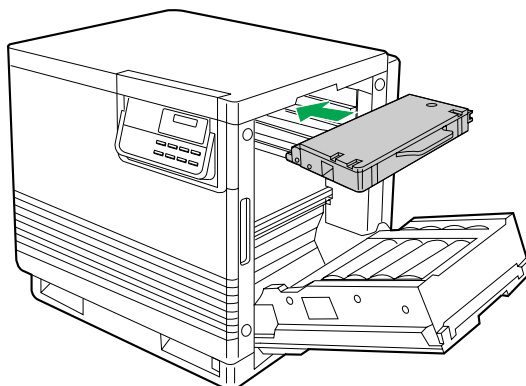

5 Repeat steps 1 to 4 for each toner developer.

When you have installed all the toner developers, go to step 6.

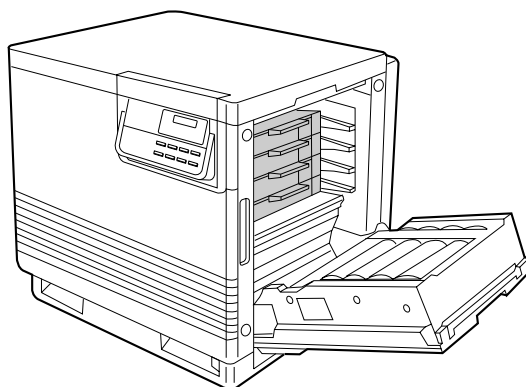

6 Close the right side cover.

Loading Media

Loading Paper or Transparencies in the Media Cassette

The printer is shipped with a media cassette (either Letter paper or A4 paper) installed. The printer can also use five different trays as options:

Cassette	Size
A4 Paper	210 mm × 297 mm
A4 Transparency	210 mm × 297 mm
Letter Paper	8.5" × 11"
Letter Transparency	8.5" × 11"
Legal Paper	8.5" × 14"

Notes:

- Make sure that you load the correct media. Each tray is designed and labelled for **only** paper or transparency. If you load the incorrect media type in a tray, it may cause a jam.
- If you have the Paper Feeder PF-81/PF-81D installed:
 - If you wish to use the automatic cassette-switching feature (for example, when doing a large print job), make sure that all cassettes in the printer are the **same** media type (paper only) and size.
 - The transparency cassette should only be inserted in the upper or middle cassette slots.

Note:

The printer does not automatically switch cassettes if the media type of the cassette is Transparency.

- 1** Pull the media cassette out of the printer.

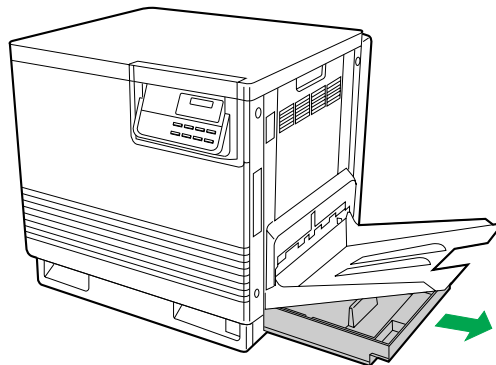

- 2 Remove the base plate stopper from inside the media cassette; refer to the instruction sheet attached to the cassette.

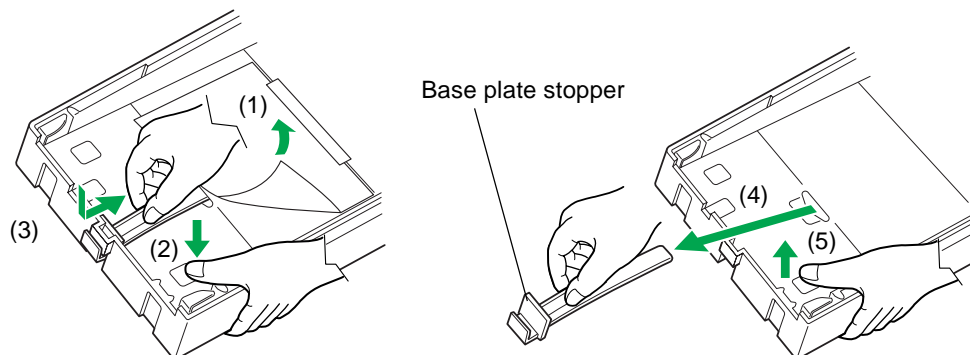

- 3 Push down on the metal plate until it clicks, locking it in place.

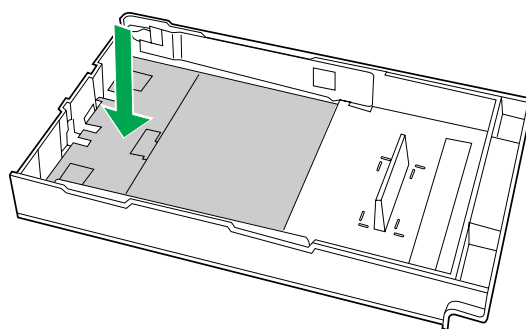

- 4 Fan the media (paper/transparencys), then tap it on a level surface to avoid media jams or skewed printing.



Notes:

- To optimize your printer's performance, always use clean, unused media.
- Be careful not to leave fingerprints on the media, which can result in a smudged print.
- Reusing media that has been fed through the printer once (for example, after jams) can reduce the life of the consumables and paper path components.
- Recommended transparency types are 3M CG3700 and 3M CG3710. If the print quality is poor, print on the other side.

5 Place the media in the cassette under the hooks.

The height of media should not exceed the limit mark on the cassette, or it may cause a jam.

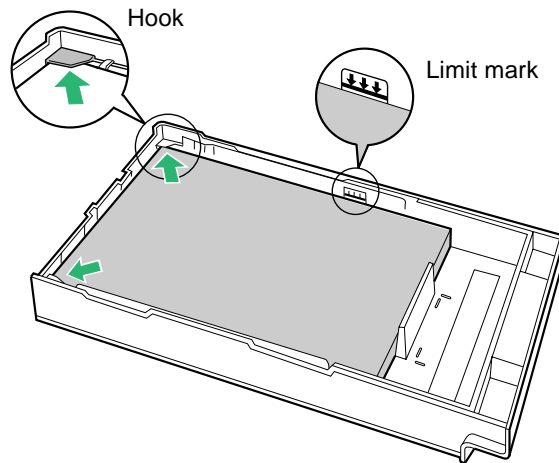

Notes:

- Load media with the print side down. Most media has instructions recommending the side to be printed first.
- Do not mix different types or thicknesses of media in the media cassette at one time; this may cause a jam.

6 Slide the media cassette all the way into the slot.

Loading Media in the Multi-purpose Tray

The multi-purpose (MP) tray serves as an additional tray for loading any type of media that ranges in size from 91 mm × 254 mm to 216 mm × 356 mm (3.6 ≤ × 10 ≤ to 8.5 ≤ × 14 ≤ inches). Use it to load a single sheet or a stack of media, depending on the media's type and thickness.

Use the multi-purpose tray to accomplish the following:

Print on standard and special media

- Standard media
Plain paper [75 to 165 g/m² (20 to 44 lbs.)]
- Special media
Label, transparency, card stock, coated paper, or the reverse side of printed paper
(The print quality may not be stable. Use the media tray for best reliability.)

Setting media thickness switch

Because the printer accommodates various media weights from the multi-purpose tray, media thickness can be manually selected for the most reliable paper-picking. Follow these steps:

- 1** Open the left side cover ((1)). The green media thickness switch is located on the paper feeder and has three settings:

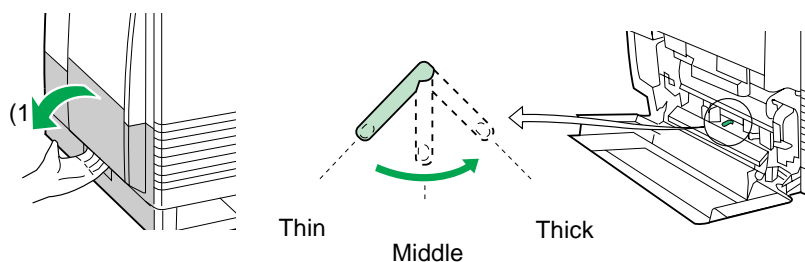

- 2** Move the switch to the desired setting.

Switch setting	Media
Thin (Default)	Laser paper 75 to 90 g/m ² (20 to 24 lbs.)
Middle	Laser paper 91 to 123 g/m ² (25 to 32 lbs.) Transparency, Label, Coated paper
Thick	Laser paper 124 to 165 g/m ² (33 to 44 lbs.)

- 3** Close the left side cover.

Selecting a multi-purpose tray mode

The multi-purpose tray has two different ways of feeding media: Cassette, and First modes. For details on selecting a mode, refer to page 46.

■ Loading Paper

Notes:

- Reusing media that has been fed through the printer (for example, after jams) can reduce the life of the consumables and paper path components.
- When printing legal size using the multi-purpose tray, backside marking may occur. If this occurs, use the legal cassette.

For detailed information on media, refer to pages 111 and 114.

- 1** Set the media thickness switch (➞ P. 19).
- 2** (1) Open the Multi-purpose tray.
(2) Extend the media support by sliding it outward.

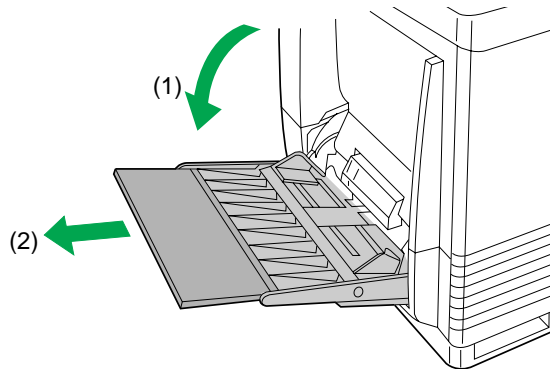

- 3** Separate the media guides to the approximate width of the media.

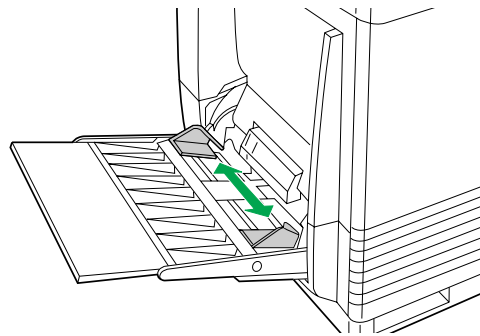

- 4** Fan the media, and then tap it on a level surface to avoid media jams or skewed printing.

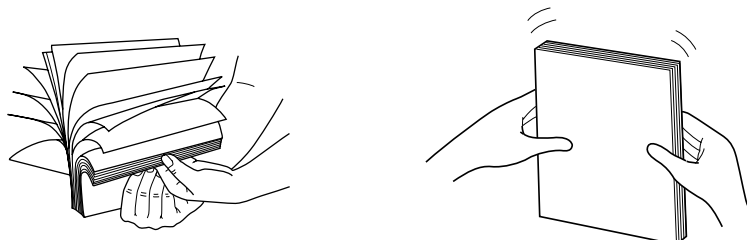

- 5** Insert the media with the printing side up into the multi-purpose tray.

The height of media should not exceed the limit mark on the left guide, or it may cause a media jam.

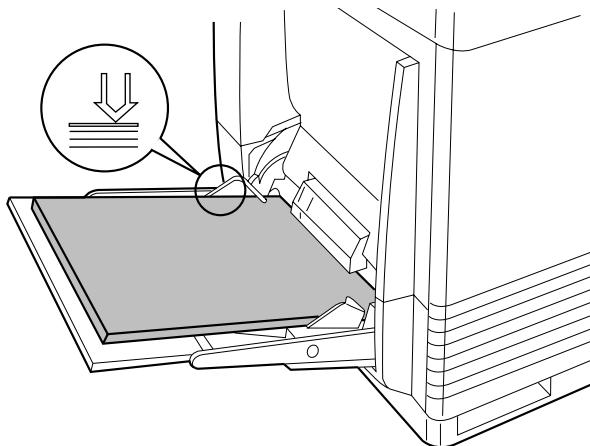

- 6** Adjust the media guides to the media size.
- 7** Use the printer driver to select the multi-purpose tray.
- 8** Open the printer driver's **Paper** tab, then pull down the **Paper Source** menu and select your media type.

Note:

If you use the MP tray and print on the second side of the thick paper, select **Card Stock** in the **Paper Source** menu, instead of **Second Side**.*

* Means the other side of a preprinted sheet.

■ Loading Label

For detailed information on labels, refer to page 114.

- 1** Set the media thickness switch ( P. 19).

- 2** Adjust the media guides to the width of the label sheets.

- 3** Load label stock into the multi-purpose tray, positioning the sheets so that the top edge feeds into the printer first and the printable side is facing up.

The height of the labels should not exceed the limit mark on the paper guide.

- 4** Open the printer driver's Paper tab, then pull down the Paper Source menu and select Label.

Connecting the Printer to a Computer

The printer can directly be connected to a computer through the parallel interface or the serial interface.

To connect the printer in a local area network, you must obtain a network interface card (☞ P. 4). For further details, consult your Kyocera dealer from which you purchased the printer.

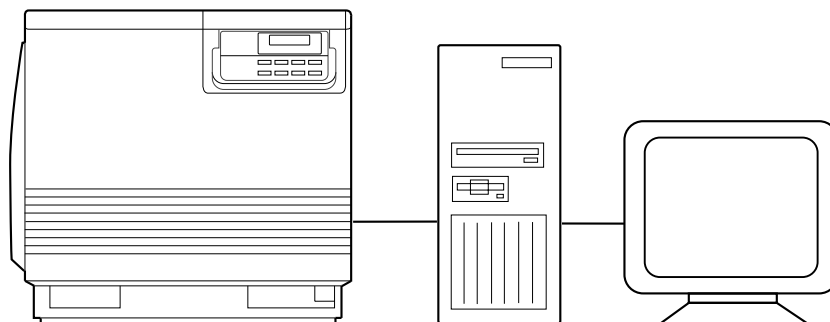

FS-5900C

Computer

Monitor

Using a Parallel Interface Cable

If you do not have a parallel interface cable, you will need to purchase one from your local computer store or dealer (☞ P. 116 for Parallel Interface specifications).

- 1** Make sure the computer, printer and the other connected peripheral devices are turned off.
- 2** Connect the parallel interface cable to the computer's parallel interface connector and the printer's parallel interface connector (marked as Parallel).

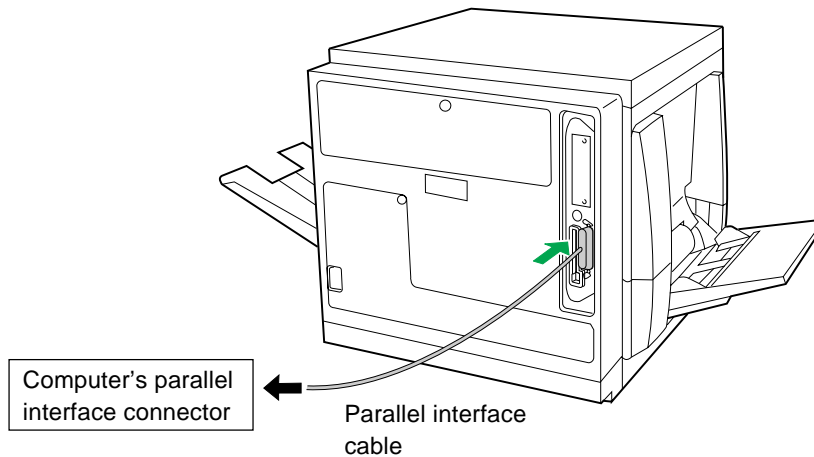

Notes:

- The actual connector on the computer may vary depending on the manufacturer of the computer. Consult the computer's documentation.
- If the cable is connected to the PC via a printer buffer or selector, the printer may not print.

- 3** Connect the power cord to the printer's AC inlet and to an AC outlet.

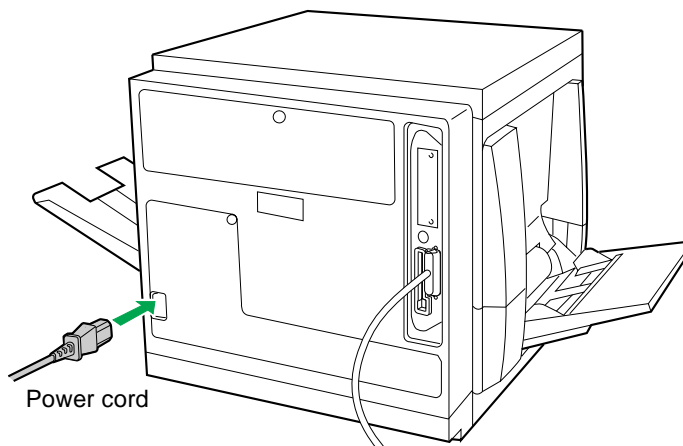

Connecting the Serial Interface

To connect the printer to a computer using the serial interface, use the XSER connector at the rear panel of the printer. The serial connector is of a round, 8-pin DIN type and you will need a cable adaptor (SA-80) if you connect a DSub type serial connector.

Barcode Reader (BC-1)

With the hard disk option (see below) installed, you can take the advantage of the Kyocera MPS (Multiple Print System). The barcode reader then allows you to recursively print the jobs cached in the hard disk by reading the barcode printed on the printed job. For more information, refer to the user's manual supplied with the barcode reader.

Installing the Hard Disk Option

The printer can be optionally installed with a hard disk kit HD-2C. Once the hard disk is installed, the printer can temporarily or permanently cache the print jobs in the hard disk so that you can print multiple collated copies quickly or take the advantage of the barcode reader system. (See the preceding section.)

Installing the hard disk option requires removal of the main controller board and mounting the hard disk on it and therefore requires a qualified technician. See your dealer from which the printer is purchased for installing the hard disk.

Power On

- 1 Turn ON the printer, then the computer. The printer's power switch is located at the bottom rear of the printer.

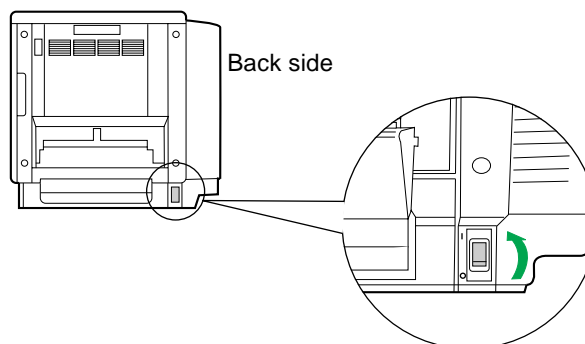

- 2 (1) All the indicators on the printer lights briefly and Self test is displayed on the printer message display.
(2) After approximately 5 minutes, the ON LINE indicator is illuminated and Ready is displayed on the printer message display.

The printer is ready for printing.

Note:

When you power on your system for the first time, if "New Hardware Found" is displayed on the computer screen, refer to page 28.

Printing a Status Page From the Printer Control Panel

The status page provides general information on printer settings and configuration. Make sure the printer is ready and paper is loaded. Use the following procedure to print a test page.

While the message display indicates Ready, press the **STATUS** key.

The printer will start printing a status page.

(Example)

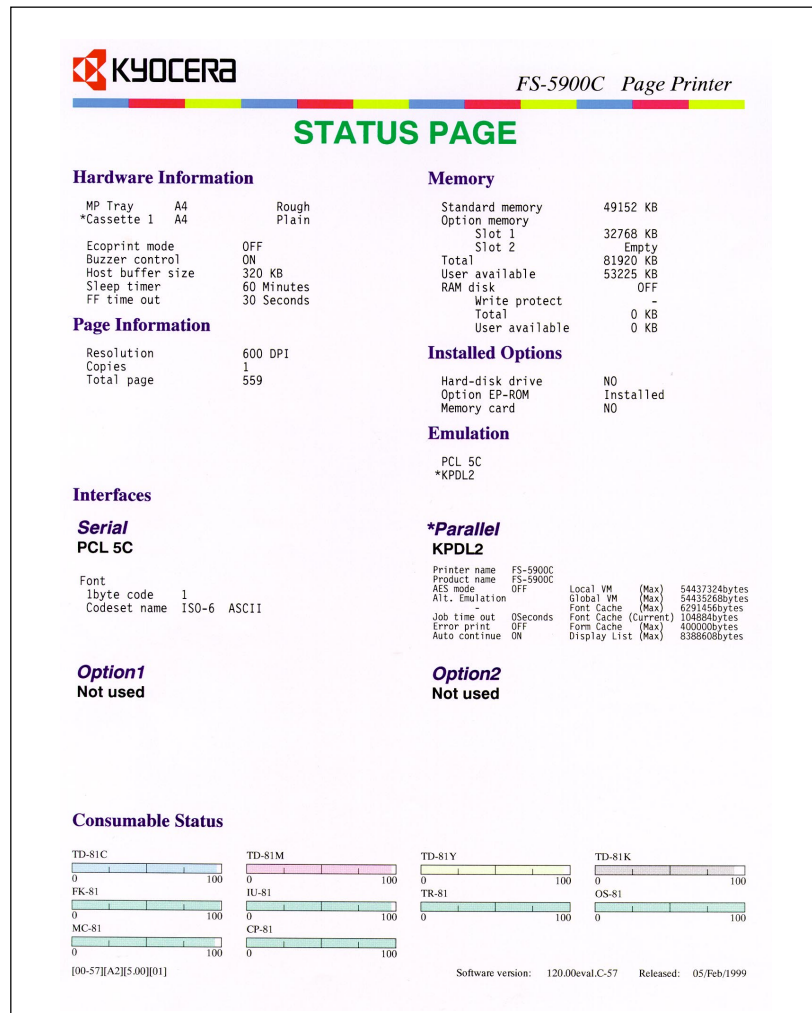

The printer can also print a different status page for service purposes. To print a service status page, see page 36, then 50.

Installing the Driver Software

The driver software installation will create the printer driver for Windows 3.1 or Windows 95/98.

See the Help file provided with the driver for how to use the printer with the driver software.

Installing the Printer Driver for Windows 3.1

- 1** Start Windows 3.1.
- 2** Quit all applications.
- 3** Insert the supplied CD-ROM into your computer's CD-ROM drive.
- 4** Double click on the Control Panel.
- 5** Double click on Printers.
- 6** Click on Add >>.
- 7** A screen for "List of Printers:" will appear. From the choices, click on Install Unlisted or Updated Printer.
- 8** Click on Install....
- 9** The install driver menu will appear. Type in your CD-ROM drive name followed by the directory path depending on the language you use:

`\\(language)\Pcl\3x\Enhanced`

For example, if you are in U.K. and your CD-ROM drive is D:, type
`D:\English\Pcl\3x\Enhanced.`
- Note:**
To install the KPDL printer driver, select "\\Kpdl" in place of "\\Pcl" in each line above.
- 10** Select Kyocera FS-5900C Enhanced from the printers displayed and click on OK. Once the driver has been installed, close the Control Panel by clicking on Close.

Installing the Printer Driver for Windows 95/ Windows 98

■ Using Plug and Play

- 1** Turn on the printer.
- 2** Turn on the computer and start Windows 95/Windows 98.
The New Hardware Found window is displayed for a few seconds, then the Update Device Driver Wizard window is displayed.
- 3** Click Next >.
- 4** Click Finish.
The Insert Disk window is displayed.
- 5** Insert the supplied CD-ROM into your CD-ROM drive.
When the Kyocera Digital Library screen starts, click EXIT.
- 6** Click OK.
The Copying Files window is displayed.
- 7** In the Copy File from field, type in your CD-ROM drive name followed by the directory path depending on the language you use:
`\\(language)\Pcl\9x\Enhanced`

For example, if you are in U.K. and your CD-ROM drive is D:, type
`D:\English\Pcl\9x\Enhanced`.
- 8** Click OK.
- 9** Click on Kyocera FS-5900C Enhanced.
- 10** Click Next >.
- 11** Follow the instructions on the screen to complete the installation.
After installation, restart your system.

Note:

The Plug and Play installation procedure varies depending on the version of Windows 95/Windows 98. Refer to Help in Windows 95/Windows 98.

■ Using Add Printer

- 1** Start Windows 95/Windows 98.
- 2** Quit all applications.
- 3** Click Start, move the pointer to Settings, then click Printers.
The Printers window is displayed.
- 4** Double click the Add Printer icon.
The Printer Wizard screen starts.
- 5** Click Next >.
- 6** Select Local printer or Network printer and then click Next>.
- 7** Click Have Disk....
- 8** Install the supplied CD-ROM into your computer's CD-ROM drive.
When the Kyocera Digital Library screen starts, click EXIT.
- 9** In the Copy File from field, type in your CD-ROM drive name followed by the directory path depending on the language you use:
`\\(language)\Pcl\9x\Enhanced`

For example, if you are in U.K. and your CD-ROM drive is D:, type
`D:\English\Pcl\9x\Enhanced`.
- 10** Click OK.
- 11** Click on Kyocera FS-5900C Enhanced.
- 12** Click Next >.
- 13** Follow the instructions on the screen to complete the installation.
After installation, restart your system.

Note:

After installing the printer driver, it will take several minutes for the printer to register and display in Printers Folder.

Setting the Colour Density

The printer panel provides an interface to adjust the density of the toner applied to the media. This makes it possible to offset changes in density that may result due to varying environmental conditions or aging of the toner or imaging unit.

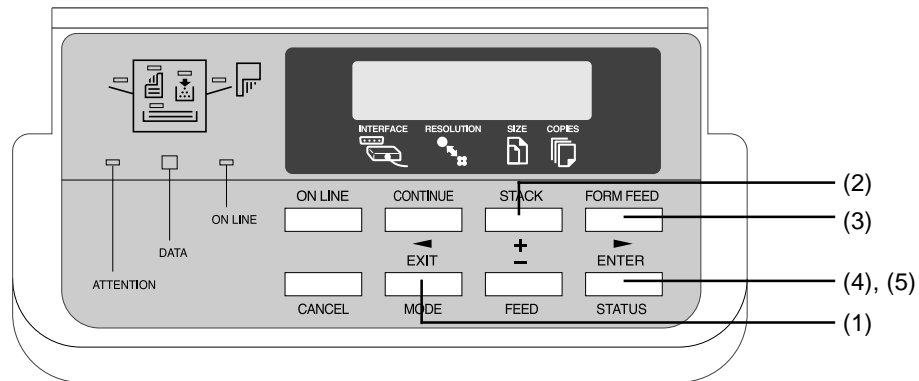

Perform the following steps to adjust the colour density:

Begin by printing a Colour Calibration Page. To print a Colour Calibration Page, proceed as follows:

- 1 (1) Press the **MODE** key on the printer panel.
- (2) Press the **+** key repeatedly until the message display indicates Colour Calibration.

```
Colour >  
Calibration
```

- (3) Press the **▶** key.
- (4) Press the **+** key until the message display shows >Print Calibration Page.

```
>Print Calibra-  
tion Page
```

- (5) Press the **ENTER** key. A question mark (?) will appear.
- (6) Press the **ENTER** key again.

A Colour Calibration Page will be printed.

The current density setting for each colour is indicated by four stripes of cyan, magenta, yellow, and black (from left to right). On the Colour Calibration Page as shown in the following example.

The factory default setting for each colour density is 10.

Colour Calibration Page (Example):

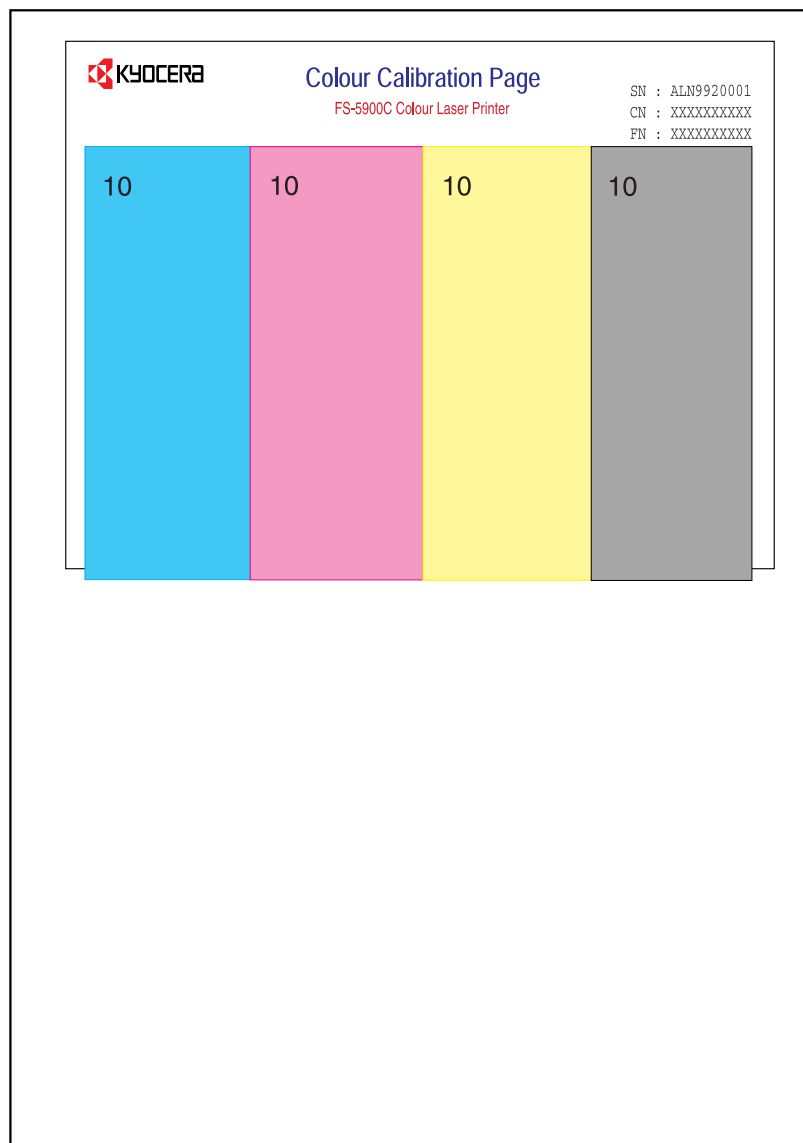

- 2** Compare the current colour density settings on the Colour Calibration Page with the colour density samples on the Colour Calibration Reference to see if they match.

Place the Colour Calibration Page on at least 2 sheets of clean white paper in a well-lighted area.

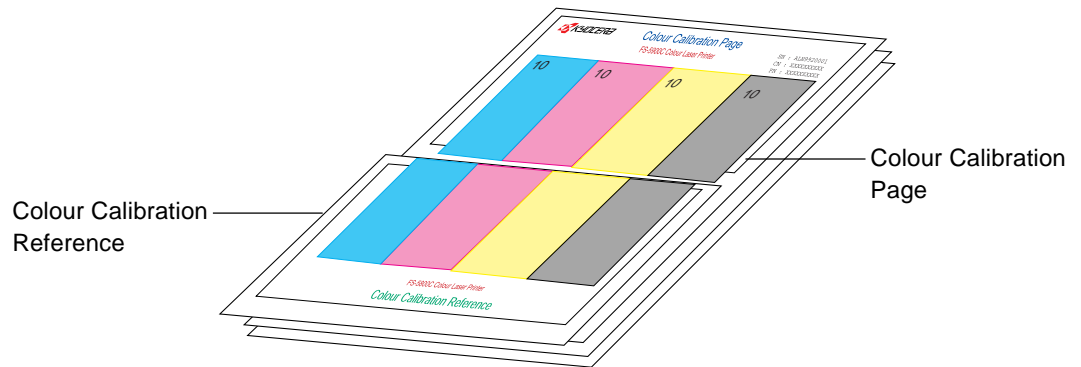

If they match, you do not need to adjust the colour density. If they do not match, go to step 3.

- 3** Press the **+** key until the message display shows >Cyan. The current density setting for cyan is indicated (the default is 10).

- (1) Press the **ENTER** key.



- (2) Press the **+** or **-** key to darken or lighten the cyan colour.

For example:

- If you wish to make the density setting darker:
 - Press the **+** button (up to 20).
- If you wish to make the density setting lighter:
 - Press the **-** button (to 00).

- (3) Press the **ENTER** key.

- 4** Press the **+** or **-** key until **>Print Calibration Page** is indicated.
- 5** Press the **ENTER** key twice to reprint the Colour Calibration Page.
 - Repeat step 3 above, if necessary.
- 6** Repeat steps 3 through 5 for each colour (**MAGENTA**, **YELLOW**, **BLACK**).
 - To skip a colour, press the **+** button.
 - To return to a previous colour, press the **-** button.
- 7** When the Colour Calibration Page and the Calibration Reference match in all four colours, press the **MODE** key to finalise the calibration procedure.

Notes:

- The colour density setting affects the average life of toner.
- Save the Colour Calibration Reference for future calibrations.

Using the Printer

Mode Selection

This section explains the menu levels and options which can be set using the **MODE** key. The **MODE** key can be used to display all of the menus in the following table.

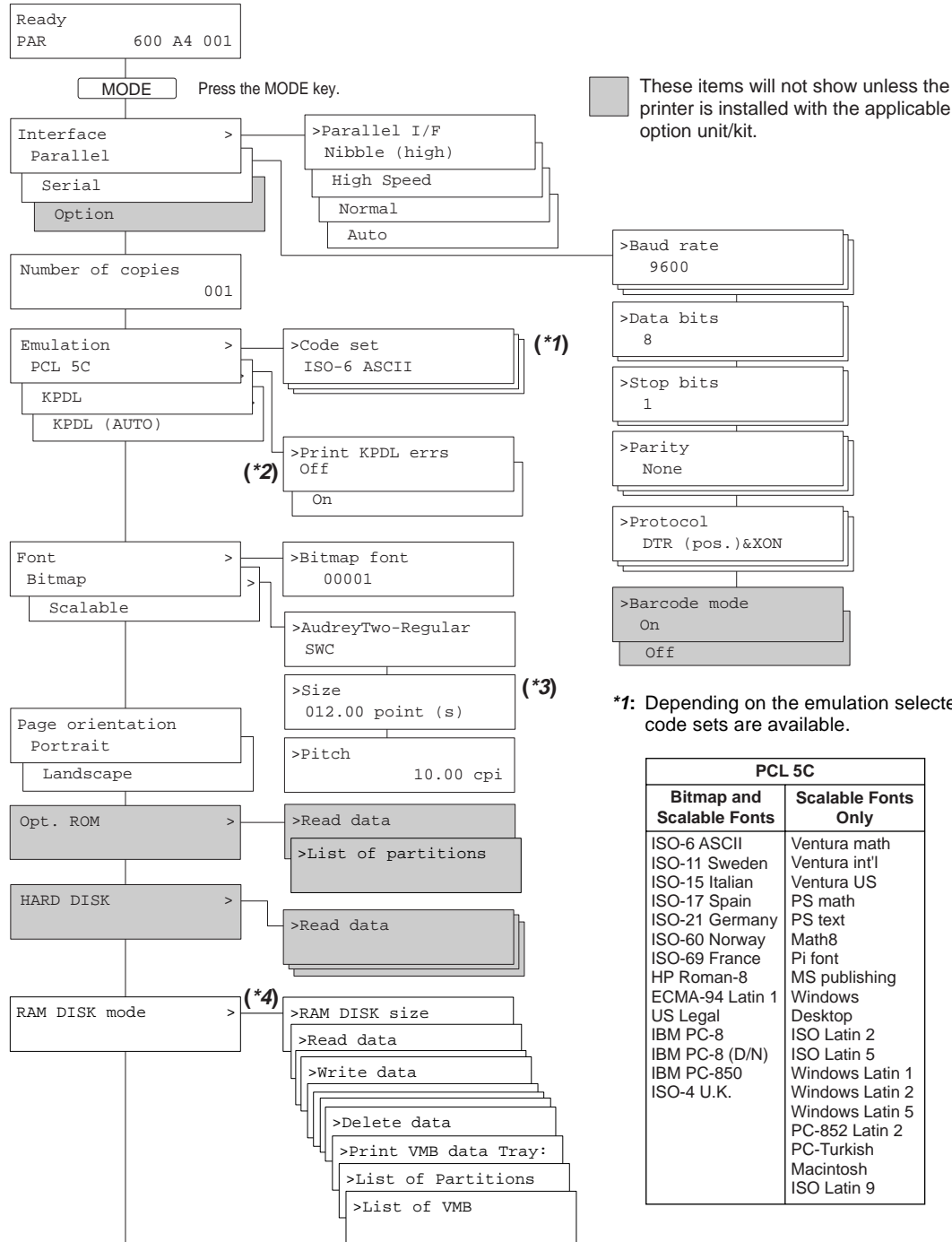

PCL 5C	
Bitmap and Scalable Fonts	Scalable Fonts Only
ISO-6 ASCII	Ventura math
ISO-11 Sweden	Ventura int'l
ISO-15 Italian	Ventura US
ISO-17 Spain	PS math
ISO-21 Germany	PS text
ISO-60 Norway	Math8
ISO-69 France	Pi font
HP Roman-8	MS publishing
ECMA-94 Latin 1	Windows
US Legal	Desktop
IBM PC-8	ISO Latin 2
IBM PC-8 (D/N)	ISO Latin 5
IBM PC-850	Windows Latin 1
ISO-4 U.K.	Windows Latin 2
	Windows Latin 5
	PC-852 Latin 2
	PC-Turkish
	Macintosh
	ISO Latin 9

Continued on next page

Continued from previous page

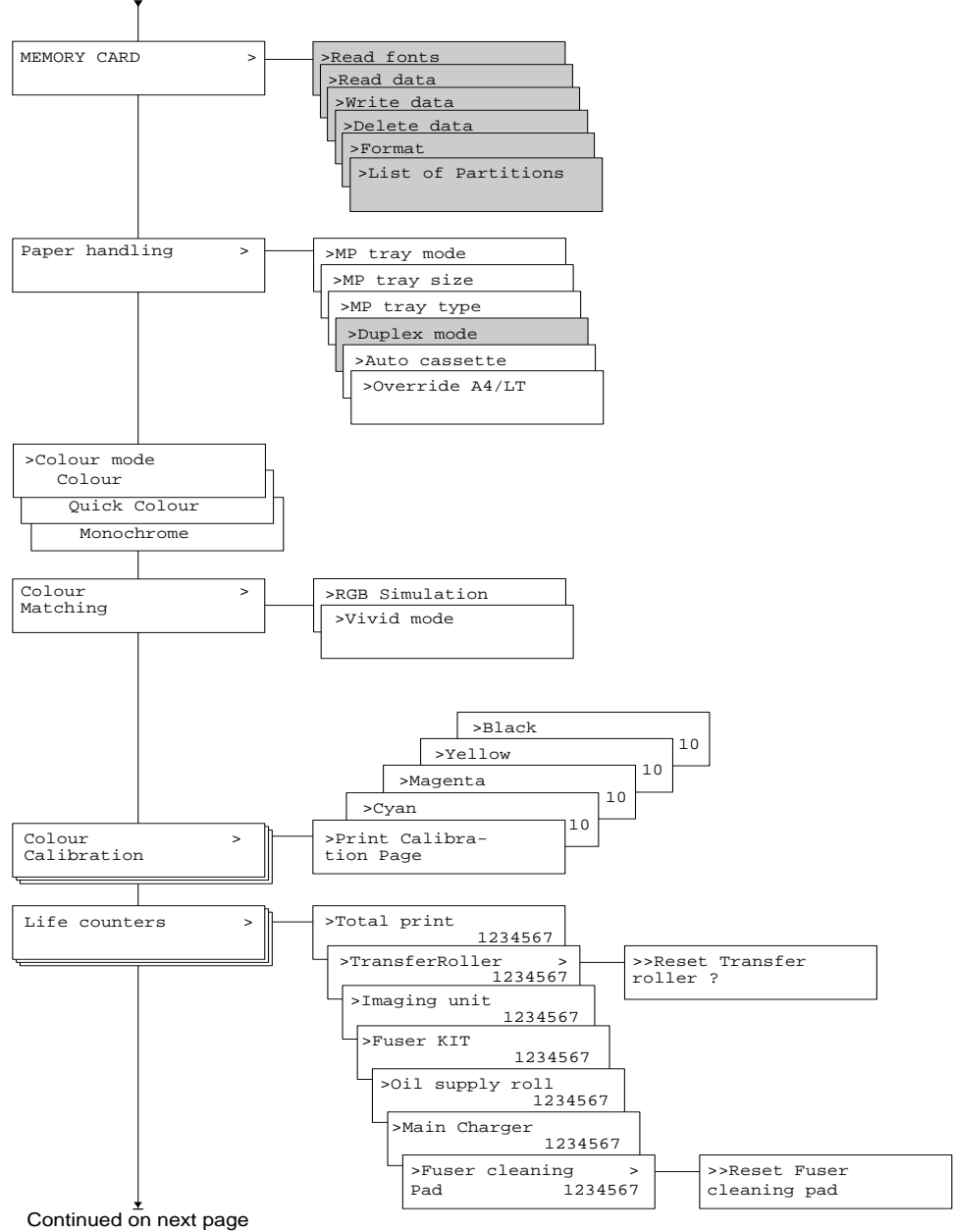

Continued on next page

Using the Printer

Continued from previous page

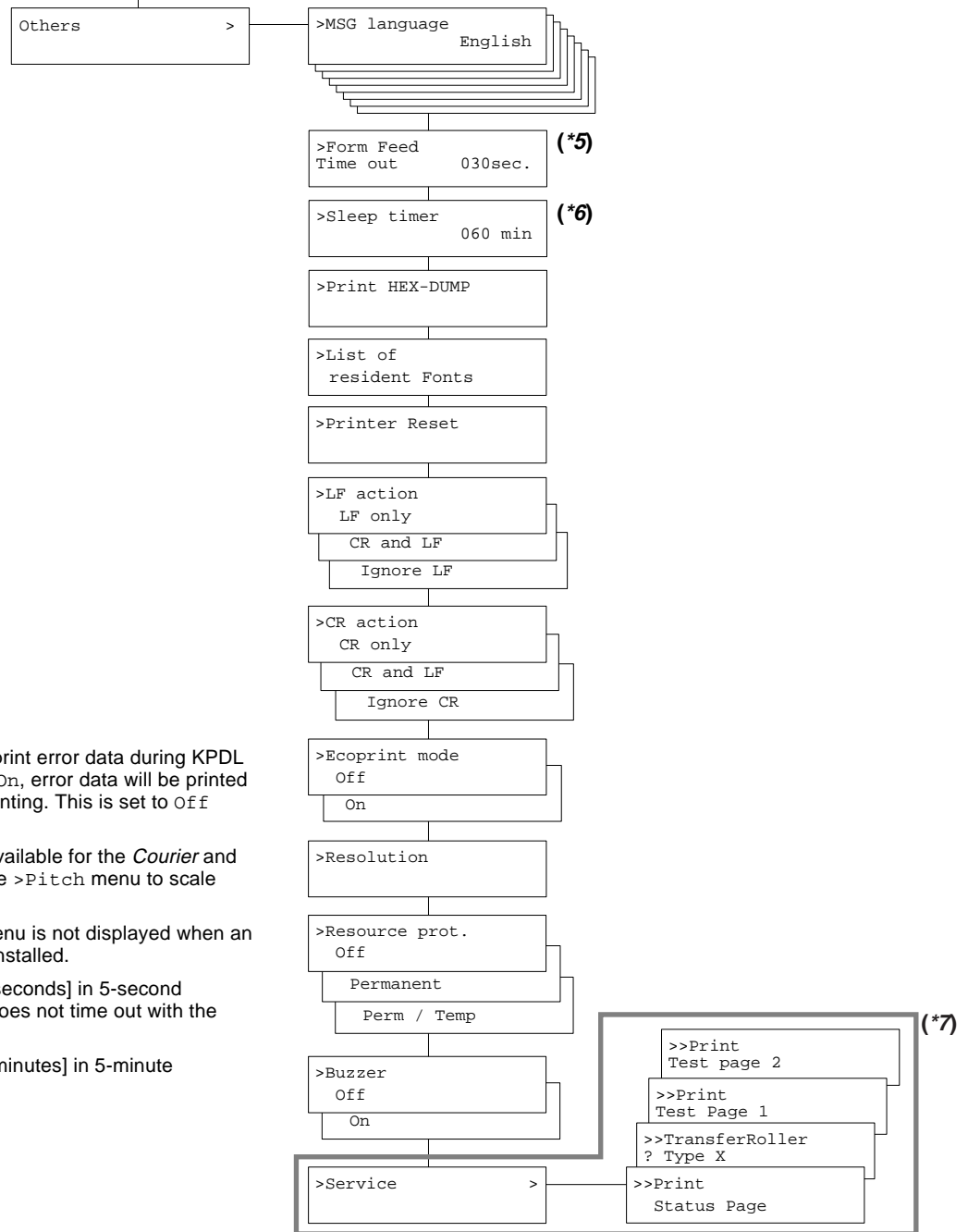

*2: The printer can be set to print error data during KPDL emulation. If this is set to On, error data will be printed if trouble occurs during printing. This is set to Off before leaving the factory.

*3: The >Size menu is not available for the *Courier* and *LetterGothic* fonts. Use the >Pitch menu to scale these fixed fonts.

*4: The RAM DISK mode menu is not displayed when an optional hard disk unit is installed.

*5: Any value from 0 to 495 [seconds] in 5-second increments. (The printer does not time out with the value set to 0.)

*6: Any value from 0 to 120 [minutes] in 5-minute increments.

*7: For service purpose only.

Navigating through the menus

The menus are in the hierarchy as shown in the diagram above. Use the **+** and **-** keys to move between menus in the same level (“vertically” in the table). The **+** key shows the next menu, while the **-** key shows the previous one. Change levels by using the **◀** and **▶** keys. The **▶** key moves to lower levels (sub-menus), while the **◀** key moves to higher levels.

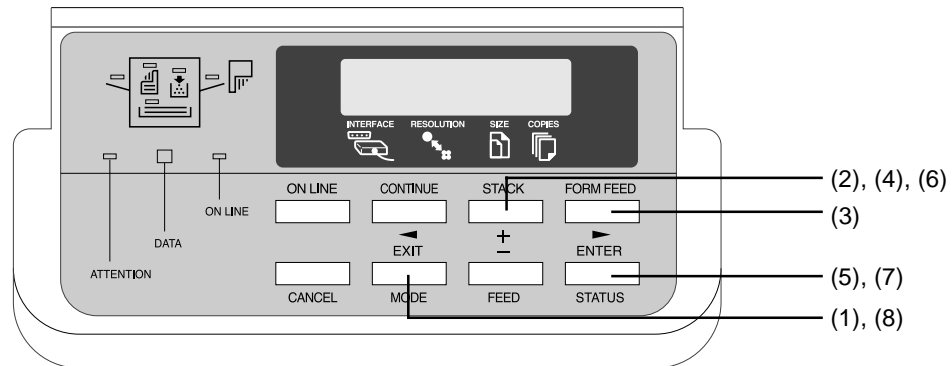

To change a specific item, for example, the sleep mode timeout time, proceed as follows:

- 1** Press the **MODE** key.
The message display will show one of the first level menus (Level 1 in the table on pages 34 to 36) depending on the previous selection.
- 2** Press **+** until **Others >** is shown on the display.
- 3** Press **▶**.
The message display will show one of the second level menus (Level 2 in the table on pages 34 to 36) belonging to the Others menu above depending on the previous selection.
- 4** Press **+** until **Sleep timer** is shown on the display.
- 5** To change the timeout value, press **ENTER**.
If you want to abandon setting, press **CANCEL**, then press **MODE**.
- 6** Press **+** repeatedly to increase the timeout time; press **-** repeatedly to decrease the timeout time until the desired timeout time (in minutes) is displayed.
- 7** Press **ENTER** to confirm the new setting.
You can abandon the new setting by pressing **CANCEL**, then **MODE**.
- 8** To quit the mode selection sequence, press **EXIT**.

Outline for Menus

■ Interface menu

The Interface menu selects one of the three printer interfaces (Option is available only if an option network interface card is installed) on which subsequent mode menu settings become effective. The Parallel and Serial options have the second level menus as described below.

Level 1	Level 2	Range		
Interface >	>Parallel I/F	Auto		
		Normal		
		High speed		
		Nibble (high)		
		Level 3	Range	
	>Serial	>Baud rate	1200, 2400, 4800, 9600 (Default), 19200, 38400, 57600, 115200	
		>Data bits	7 or 8 (Default)	
		>Stop bits	1 (Default) or 2	
		>Parity	None (Default), Odd, Even, Ignore	
		>Protocol	DTR (pos.) & XON (Default), DTR (positive), DTR (negative), XON/XOFF, ETX/ACK	
>Barcode mode*1		Off (Default) and On		
	>Option*2			

*1Available only when the optional harddisk is installed in the printer.

*2Displayed only when network board or other option board installed.

Parallel Interface Mode

The parallel interface mode of this printer supports a bi-directional/high-speed mode.

Display	Description
Nibble (high)	The parallel interface is in high-speed/bi-directional mode in compliance with the IEEE1284 standard (Default).
Auto	The printer automatically changes its communication mode to the one the host computer is using.
Normal	The parallel interface is configured according to standard specifications. Use this setting when conventional timing must be used.
High speed	The parallel interface is in high-speed mode.

After setting the interface, be sure to reset the printer or turn the power off at least once. The new setting will be enabled thereafter.

■ Number of copies

The `Number of copies` menu sets the number of copies to be printed.

Level 1	Range
Number of copies	001 (Default) to 999

■ Emulation

The `Emulation` menu switches the printer emulation. KPDL is the Kyocera's implementation of the Adobe's PostScript language. KPDL (AUTO) automatically switches the printer emulation.

Level 1	Range
Emulation	PCL 5C
	KPDL
	KPDL (AUTO)

Notes:

- For details about the emulation menu, see the table marked “*1” on page 34.
- The printer can be set to print error data during KPDL emulation. If this is set to `On`, error data will be printed if trouble occurs during printing. This is set to `Off` before leaving the factory.

■ Font

The `Font` menu selects the printer font. The fonts available vary depending on the emulation.

Level 1	Range	Options	Description
Font	Bitmap	Fontnumber	See <code>Font Number</code> on list of resident fonts that can be printed by referring to <code>List of Resident Fonts</code> (⇨ P. 48).
		Scalable	See the tables on pages 41 to 42.
	Scalable	Size	004.00 to 999.75 (points)
		Pitch	00.44 to 99.99 (dpi)

Note:

The `>Size` menu is not available for the `Courier` and `LetterGothic` fonts. Use the `>Pitch` menu to scale these fixed fonts.

For example, to select the 10-point `Dutch801-RomanSWM`:

- 1 Press **MODE**.
- 2 Press the **+** key repeatedly until the message display shows `Font >`.
- 3 If the `Font >` menu shows `Scalable`, proceed to step 4. If it shows `Bitmap`, press **ENTER** (The question mark appears blinking), press **+** (`Bitmap` changes to `Scalable`), then press **ENTER** (The question mark disappears).
- 4 Press the **▶** key. The current scalable font is indicated.

Using the Printer

- 5** Press **ENTER**.
- 6** Press the **+** key repeatedly until the font name of Dutch801-RomanSWM is displayed.
- 7** Press **ENTER** to confirm the font selection. Press **CANCEL** to abandon the selection.
- 8** Press **MODE**. This finalizes the mode menu.

Resident Scalable Fonts

This is a sample of Audrey Two-RegularSWC font.

This is a sample of Clarendon-CondensedSWC font.

This is a sample of Courier-BoldItalicSWC font.

This is a sample of Courier-BoldSWC font.

This is a sample of Courier-ItalicSWC font.

This is a sample of Courier-SWC font.

This is a sample of Dutch801-BoldItalicSWM font.

This is a sample of Dutch801-BoldSWM font.

This is a sample of Dutch801-ItalicSWM font.

This is a sample of Dutch801-RomanSWM font.

This is a sample of Dutch801SWC-Bold font.

This is a sample of Dutch801SWC-BoldItalic font.

This is a sample of Dutch801SWC-Italic font.

This is a sample of Dutch801SWC-Roman font.

This is a sample of Flareserif821-ExtraBoldSWC font.

This is a sample of Flareserif821-RomanSWC font.

This is a sample of Incised901SWC-Black font.

This is a sample of Incised901SWC-Italic font.

This is a sample of Incised901SWC-Roman font.

This is a sample of LetterGothic-BoldSWC font.

This is a sample of LetterGothic-ItalicSWC font.

This is a sample of LetterGothic-SWC font.

⌘ ⚑ ⚒ ⚓ ⚔ ⚕ ⚖ ⚗ ⚘ ⚙ ⚚ ⚛ ⚜ ⚝ ⚞ ⚟ ⚠ ⚡ ⚢ ⚣ ⚤ ⚥ ⚦ ⚧ ⚨ ⚩ ⚪ ⚫ ⚬ ⚭ ⚮ ⚯ ⚰ ⚱ ⚲ ⚳ ⚴ ⚵ ⚶ ⚷ ⚸ ⚹ ⚺ ⚻ ⚼ ⚽ ⚾ ⚿ ◈ ◉ ◊ ◌ ◍ ◎ ● ◐ ◑ ◒ ◓ ◔ ◕ ◖ ◗ ◘ ◙ ◚ ◛ ◜ ◝ ◞ ◟ ◠ ◡ ◢ ◣ ◤ ◥ ◦ ◧ ◨ ◩ ◪ ◫ ◬ ◭ ◮ ◯ ◰ ◱ ◲ ◳ ◴ ◵ ◶ ◷ ◸ ◹ ◺ ◻ ◼ ◽ ◾ ◿

(This is a sample of MoreWingbats-RegularSWM font.)

This is a sample of OriginalGaramondSWC-Bold font.

This is a sample of OriginalGaramondSWC-BoldItalic font.

This is a sample of OriginalGaramondSWC-Italic font.

This is a sample of OriginalGaramondSWC-Roman font.

This is a sample of Ribbon131-RomanSWC font.

This is a sample of Swiss721-BoldObliqueSWM font.

This is a sample of Swiss721-BoldSWM font.

This is a sample of Swiss721-ObliqueSWM font.

This is a sample of Swiss721-SWM font.

This is a sample of Swiss742SWC-Bold font.

This is a sample of Swiss742SWC-BoldCondensed font.

This is a sample of Swiss742SWC-BoldCondensedItalic font.

This is a sample of Swiss742SWC-BoldItalic font.

This is a sample of Swiss742SWC-Italic font.

This is a sample of Swiss742SWC-ItalicCondensed font.

This is a sample of Swiss742SWC-Roman font.

This is a sample of Swiss742SWC-RomanCondensed font.

Τηισ ισ α σαμπλε οφ Σψμβολ-Σετ-ΣΩΜ φοντ.

(This is a sample of Symbol-Set-SWM font.)

This is a sample of ZapfHumanist601SWC-Bold font.

This is a sample of ZapfHumanist601SWC-BoldItalic font.

This is a sample of ZapfHumanist601SWC-Demi font.

This is a sample of ZapfHumanist601SWC-Demitalic font.

Using the Printer

KPDL Fonts

This is a sample of Century-Schoolbook-SWA font.

This is a sample of Century-Schoolbook-ItalicSWA font.

This is a sample of Century-Schoolbook-BoldSWA font.

This is a sample of Century-Schoolbook-BoldItSWA font.

This is a sample of Courier-SWA font.

This is a sample of Courier-ItalicSWA font.

This is a sample of Courier-BoldSWA font.

This is a sample of Courier-BoldItalicSWA font.

This is a sample of Dutch801-RomanSWA font.

This is a sample of Dutch801-ItalicSWA font.

This is a sample of Dutch801-BoldSWA font.

This is a sample of Dutch801-BoldItalicSWA font.

This is a sample of ITC-Avant-Garde-BookSWA font.

This is a sample of ITC-Avant-Garde-BookObliqueSWA font.

This is a sample of ITC-Avant-Garde-DemiSWA font.

This is a sample of ITC-Avant-Garde-DemiObliqueSWA font.

This is a sample of ITC-Bookman-LightSWA font.

This is a sample of ITC-Bookman-LightItalicsSWA font.

This is a sample of ITC-Bookman-DemiSWA font.

This is a sample of ITC-Bookman-DemiItalicSWA font.

This is a sample of ITC-Zapf-Chancery-MediumItSWA font.

***▲*▲⊗▲⊙□●*⊗□☆*+⊗*⊗□⊗⊗*⊗*⊗⊙▼▲⊗*⊗⊗⊗□■▼⊗

(This is a sample of ITC-Zapf-Dingbats-SWA font.)

This is a sample of Swiss721-SWA font.

This is a sample of Swiss721-ObliqueSWA font.

This is a sample of Swiss721-BoldSWA font.

This is a sample of Swiss721-BoldObliqueSWA font.

This is a sample of Swiss721-NarrowSWA font.

This is a sample of Swiss721-NarrowObliqueSWA font.

This is a sample of Swiss721-NarrowBoldSWA font.

This is a sample of Swiss721-NarrowBoldObliqueSWA font.

Τηισ ισ α σαμπλε οφ Συμβολ-Σετ-ΣΩΑ φοντ.

(This is a sample of Symbol-Set-SWA font.)

This is a sample of Zapf-Calligraphic801-SWA font.

This is a sample of Zapf-Calligraphic801-ItalicSWA font.

This is a sample of Zapf-Calligraphic801-BoldSWA font.

This is a sample of Zapf-Calligraphic801-BoldItSWA font.

■ Page orientation

The `Page orientation` menu switches between portrait and landscape page orientations.

Level 1	Range
Page orientation	Portrait (Default)
	Landscape

■ Option ROM

The `Option ROM` menu reads data in the option ROM and prints a list of them as *partitions*. This menu is available only when the option ROM is installed internally with the printer.

Level 1	Range
Opt. ROM	Read data
	List of partitions

■ Harddisk

The `HARD DISK` menu reads, writes, and deletes data on the option harddisk. It also allows formatting the disk and printing a list of the contents. This menu is available only when the harddisk option is installed in the printer (See *Installing the Harddisk Option* [↖ P.25]).

Level 1	Level 2
HARD DISK	Read data
	Write data
	Delete data
	Print VMB data Tray:
	List of partitions
	List of VMB

■ RAM DISK mode

The `RAM DISK mode` menu configures an arbitrary amount of memory as a RAM disk for use with virtual mail boxes (↖ P.52) and reading or writing data.

Level 1	Level 2
RAM DISK mode	RAM DISK size
	Read data
	Write data
	Delete data
	Print VMB data Tray:
	List of Partitions
	List of VMB

Using the Printer

■ Memory card

The MEMORY CARD menu reads, writes, and deletes data on the memory card. It also allows formatting the memory card and printing a list of the contents. This menu is available only when a memory card is inserted into the memory card slot at the back of the printer (☞ P. 57). For instructions on using these submenus, refer to page 57.

Level 1	Level 2
MEMORY CARD >	Read fonts
	Read macro
	Read data
	Write data
	Delete data
	List of Partitions

■ Colour mode

This setting controls whether the page is printed in Colour (four-colour), Quick Colour (three-colour), or in Monochrome (black and white gray scale).

Level 1	Range
Colour mode	Monochrome
	Colour (Default)
	Quick Colour

■ Colour matching

The Colour matching menu provides three colour matching functions to accurately represent the original colour by giving different rendering intents.

Level 1	Options
Colour matching	RGB Simulation
	Vivid mode

For details on each colour matching function, see the table below:

Colour matching mode	Description
RGB Simulation	Printing is done using colours most closely approximate the monitor colours. Select the type of monitor being used. (If your monitor is not listed, set Custom values as appropriate for your monitor. See the monitor documentation for appropriate values.)
Vivid mode	Adjusts the brightness of colours.

■ Colour calibration

This menu provides an interface to adjust the density of the toner applied to the media. For details on how to calibrate toner density, see [Setting the Colour Density](#) (P. 30).

Level 1	Level 2	Range
Colour Calibration	Print Calibration page	
	Cyan	00 to 20
	Magenta	00 to 20
	Yellow	00 to 20
	Black	00 to 20

■ Life counters

The Life counter menu displays the printer's page count and the supply consumption status. This helps you know how soon you will need to replace the supplies listed below.¹ The `Reset transfer roller` and `Reset cleaning pad` options should be used after replacing the transfer roller. Selecting this option resets the transfer roller counter to '0000000.'

Level 1	Level 2	Range	Level 3
Life counters	Total print	0000000 to 9999999 pages	
	TransferRoller	0000000 to 9999999 pages	Reset transfer roller
	Imaging unit	0000000 to 9999999 images	
	Fuser KIT	0000000 to 9999999 pages	
	Oil supply roll	0000000 to 9999999 pages	
	Main Charger	0000000 to 9999999 pages	
	Fuser Cleaning Pad	0000000 to 9999999 pages	Reset Fuser Cleaninig Pad

¹ When a supply item is replaced with a new one, the printer automatically resets the page counter for that item to '0000000.'

Using the Printer

■ Paper handling mode

The Paper handling mode allows the MP tray to be configured in the same manner as with the media cassette.

Level 1	Level 2	Options
Paper handling	MP tray mode	Cassette
		First (Default)
	MP tray size	B5
		ISO B5
		A4
		Executive
		Letter
		Legal
	MP tray type	Plain (Default)
		Transparency
		Labels
		Cardstock
		Coated
		2nd side
	Duplex mode	none (Default)
		Short edge bind
		Long edge bind
	Auto cassette	None (Default)
		Size select
		1 & 2*
		1 & 3*
		2 & 3
		1 & 2 & 3*
Override A4/LT	On	
	Off (Default)	

* Not selectable if the duplex unit is installed.

MP tray mode

First mode

The printer automatically feeds any paper placed on the multi-purpose tray even if another paper source is currently selected. After the paper in the multi-purpose tray is printed, paper will be fed from the paper source originally set. This is the factory set default. This mode is useful when printing on a special kind of paper followed by a normal sheet in the media cassette.

Cassette mode

Approximately 100 sheets of paper can be continuously fed.

Note:

In `First` mode, printing is carried out using custom size paper feed timing regardless of the `MP tray size` setting.

MP tray type

When cassette is selected as the MP tray mode, the paper source is automatically selected according to the print data. Set `MP tray size` and `MP tray type` to match the type of paper to be loaded into the MP tray. If received print data does not match the type of paper loaded in the paper source, the printer displays an error message (P.93) and printing is interrupted.

When this occurs, printing can be resumed by loading the type of paper indicated by the error message into the MP tray and pressing the `CONTINUE` key.

Auto cassette mode

The `Auto cassette` mode is available only when the printer is installed with the optional paper feeder. This menu selects one of the automatic paper cassette switching modes for normal paper. The numbers below refer the media cassettes of the printer and the option paper feeder: 1 for the upper cassette; 2 for the middle cassette; and 3 for the lower cassette. The `Size select` automatically searches all media cassettes for the paper size commanded by the document.

Note:

The printer does not switch cassettes automatically if the media is transparency.

Override A4/LT

This sets whether to enable or disable the difference between A4 size and letter size. Under the default setting of `Off`, the paper size of the paper source is matched to the paper size given for the data, and if these differ a corresponding error message is displayed. When this is set to `On`, printing is performed even if the actual paper size differs from the paper size given for the data.

Other menus (Others)

The following settings are available by selecting `Others` at the end of the main menu. To enter one of these menus, press the **▶** key, then the **+** (or **-**) key.

■ Message language

The `MSG language` menu selects the language of the messages on the message display.²

Level 1	Level 2	Range
Others	MSG language	English, French, German, Italian, Danish, Spanish, Swedish, Japanese

² Messages in different languages can be added by installing a ROM inside the printer electronics or inserting a PC card in the printer's PC card slot. For more information, see your printer dealer.

Using the Printer

■ Formfeed timeout time

The `Formfeed timeout time` menu adjusts the time-out time for the occurrence of the printer's formfeed action. Absence of data for this period of time causes a formfeed.

Level 1	Level 2	Range
Others	Form feed time out	000 to 495 (seconds)

Note:

Any value from 0 to 495 [seconds] in 5-second increments. (The printer does not time out with the value set to 0.)

■ Sleep timer

The `Sleep timer` menu adjusts the period of time after which the printer's sleep function is activated. During "sleeping," all indicators and the ventilating fans will go off, conserving electricity, until an operation is made from the control panel or print data is received.

Level 1	Level 2	Range
Others	Sleep timer	000 to 120 (minutes)

Note:

Any value from 0 to 120 [minutes] in 5-minute increments.

■ Print HEX-DUMP

The `Print HEX-DUMP` menu prints formatted hexadecimal data codes for debugging programs and files.

Level 1	Level 2	Range
Others	Print HEX-DUMP	(To print in debugging mode, press ENTER twice.)

■ List of resident fonts

The `List of resident fonts` menu prints a list of all resident fonts in the printer on several pages.

Level 1	Level 2	Range
Others	List of resident fonts	(To print a list of resident fonts, press ENTER twice.)

■ Printer Reset

The `Printer Reset` menu brings all temporary printer settings back to their default values. Note that resetting the printer also removes all temporarily downloaded resources such as fonts and macros from its memory.

Level 1	Level 2	Range
Others	Printer Reset	(To reset the printer, press ENTER twice.)

■ LF action

The `LF action` menu selects the line feed action from the following options.

Level 1	Level 2	Range
Others	LF action	LF only, CR and LF, Ignore LF

■ CR action

The `CR action` menu selects the carriage return action from the following options.

Level 1	Level 2	Range
Others	CR action	CR only, CR and LF, Ignore CR

■ Ecoprint mode

The `Ecoprint mode` menu switches Ecoprint on or off. The Ecoprint enables you to reduce the amount of toner consumed on the page, saving your printing cost.

Level 1	Level 2	Range
Others	Ecoprint mode	On, Off

■ Resolution

The `Resolution` menu sets the resolution of the printer.

Level 1	Level 2	Range
Others	Resolution	600 dpi 1200 dpi*

Note:

* The 1200 dpi setting can be selected only when using KPDLE emulation.
With emulation modes other than KPDLE, 600 dpi is selected automatically.

Using the Printer

■ Resource protection

The `Resource protection` menu enables the resource protection function in the following options. The resource protection function preserves PCL resources in memory so that they are intact even when you change the emulation from KPDL (or KPDL [AUTO]) back to PCL 5C.

Level 1	Level 2	Range
Others	Resource prot.	Off, Permanent, Perm/Temp

■ Audio alarm

The `Buzzer` menu turns on the audio alarm which sounds according to the printer error.

Level 1	Level 2	Range
Others	Buzzer	Off, On

■ Service

The `Service` menu prints a special status page and colour test pages to diagnose problems. The `Print Test Page 1` prints a CMYK test page; and the `Print Test Page 2` prints four pages, each printed in cyan, magenta, yellow, or black.

Level 1	Level 2	Level 3
Others	Service	Print Status Page, Transfer Roller, Print Test Page 1, Print Test Page 2

Note:

For service purpose only.

RAM DISK

A RAM DISK can be set up as a virtual media device by setting a given amount of the total printer memory as the RAM DISK. This can then be used for reading and writing data just as with a memory card or as a virtual mail box function (see page 52 to 56).

Note however that data written to the RAM DISK is lost if the printer is reset or its power turned off. RAM DISK settings can be made from the printer's control panel.

Notes:

- The RAM DISK is set from the printer's user memory. The printer's printing speed may therefore drop or insufficient memory errors result depending on the value of the RAM DISK setting.
- RAM DISK functions cannot be used if an optional hard disk unit is installed.

■ Setting the RAM DISK Size

- 1** Press the **MODE** key.
- 2** Press the + or - key and select RAM DISK mode >.
- 3** The default setting is Off. Pressing the **ENTER** key will cause a ? to flash. Press the + or - keys to display On and then press the **ENTER** key.
- 4** Press the ► key to display >RAM DISK size.
- 5** Press the **ENTER** key again, and change the RAM DISK size using the + or - key. It is not possible to make a setting that exceeds total printer memory. The default value for the RAM DISK is the total printer memory minus 32 MB. This parameter may be set anywhere from 01 to 80 depending on the available printer memory. Press the **EXIT** key if you want to cancel the setting.
- 6** Once the desired RAM DISK size is displayed, press the **ENTER** key.
- 7** Press the **EXIT** key. Then turn the printer's power off and on again. The setting will be activated after restart.

■ RAM DISK Operations

The following operations are available with the RAM DISK.

- Read Data
- Write Data
- Delete Data
- Print a List of Data Names
- Print Accumulated VMB Data
- Print VMB List

Except for printing accumulated VMB data and printing a VMB list, procedures for all operations are the same as for a memory card. Please see the memory card item for the given procedure.

Virtual Mail Box (VMB)

The Virtual Mail Box (VMB) function is a mail box function for the printer which does not require a physical mail box to be attached to the printer. The virtual mail box function can be used when RAM DISK mode is On or when an optional hard disk unit is installed on the printer. (The RAM DISK cannot be used when the optional hard disk is installed.) This manual describes how to use the virtual mail box with a RAM DISK.

With a virtual mail box, unlike a physical mailbox, data sent from the computer is stored in the RAM DISK as rasterized data. This stored data accumulates in a numbered virtual output tray. When it is time to actually print the data, it is printed by specifying the virtual output tray number where the data is stored using the printer's control panel or an optional barcode reader (BC-1).

Note:

If all the data in a virtual output tray is printed, all data in that tray will be deleted. If printing is halted by pressing the **CANCEL** key during printing, data in that tray will not be deleted. Data is not deleted unless all data in the virtual output tray is printed.

- **Locked mailbox**

Allowing a password to be set for the virtual output tray, this feature makes the printout of confidential documents easy.

- **Multilevel mailbox**

Supporting up to 255 virtual output trays, mail boxes can be allocated at the individual level rather than by the user's job title or group.

- **Large capacity mailbox**

There is no limit on the size per virtual output tray. Since the only limit is on the total size of all trays, all of the RAM DISK can be used.

■ Outputting to a VMB

When sending data to a virtual output tray set within the RAM DISK, make this setting from the printer driver. With this setting, data can be sent by specifying the desired virtual output tray number. It is also possible to assign a name to a virtual output tray and send data by specifying that name. (For details on this setting, please refer to the help documentation for the printer driver.)

When data is sent by specifying a virtual output tray, printing to paper is not performed at the time data is sent. Sent data accumulates in the virtual output trays of the RAM DISK. For details on printing accumulated data, please see the next item.

■ Print Accumulated VMB Data

This function prints VMB data accumulated in a virtual output tray.

- 1** Select RAM DISK mode on the printer's Mode Select Menu and display >Print VMB data Tray. The VMB tray number will appear in the location marked by #'s below, while the VMB tray name will appear in the location marked by %'s.

```
>Print VMB data
Tray###:%%%%%%%%
```

- 2** Pressing the **ENTER** key will cause a ? to flash.

```
>Print VMB data
Tray###?%%%%%%%%
```

- 3** Each time the + or - keys are pressed, the VMB data display will change. Press the **CANCEL** key if you want to halt printing. The ? display will disappear.
- 4** Display the VMB data you want to print. Pressing the **ENTER** key will cause Processing to be displayed and the data will be printed.

■ Print Accumulated VMB Data with a Password

This function prints VMB data protected by a password which has accumulated in a virtual output tray.

- 1** Display >Print VMB data Tray. The VMB tray number will appear in the location marked by #'s below, while the VMB tray name will appear in the location marked by %'s.

```
>Print VMB data
Tray###:%%%%%%%%
```

- 2** Pressing the **ENTER** key will cause a ? to flash.

```
>Print VMB data
Tray###?%%%%%%%%
```

- 3** Each time the + or - keys are pressed, the VMB data display will change. Press the **CANCEL** key if you want to halt printing. The ? display will disappear.
- 4** If a password is set for the VMB data you want to print, the message display will change to >User ID? 00001 and the printer will standby to accept a password. The cursor will blink in the one's place of the displayed number. Enter the correct password. Use the ◀ and ▶ keys to change places and the + or - keys to change the displayed number. Passwords from 00001 to 65535 can be entered.
- 5** Press the **ENTER** key once the correct password is entered. Processing will be displayed and the data will be printed. If the password was incorrect, an error message "RAM DISK error 86" will be displayed. (See page 97) Pressing the **CONTINUE** key will return the printer to Ready status.

Note that the password entered here is reset (returns to 00001) when this mode is exited.

■ Print VMB Accumulated Data List

This feature prints a list of VMB data accumulated in the RAM DISK.

1 Display >List of VMB.

```
>List of VMB
```

2 Pressing the **ENTER** key will cause a ? to display.

```
>List of VMB ?
```

Press the **CANCEL** key if you want to halt printing. The ? display will disappear.

3 Pressing the **ENTER** key will cause Processing to be displayed and the VMB data list to be printed.

Bin No.	Alias	Jobs	Pages	Normal/Shared Size(KB)	Output (1)	Delete (1)
1	Kyocera	2	6	58 /	0	
2	Honda	0	0	0 /	0	
3	Softman	3	9	89 /	0	

An actual VMB list printout will differ slightly from sample given above.

Information regarding virtual output trays which are set will be displayed in the virtual mail box list. A - mark is shown with the bin number for virtual output trays which contain data. If a password is set for a virtual output tray, there is no barcode shown for that virtual output tray. Also, "FULL!!" will be shown for virtual output trays for which there was an error when data was sent to them. A VMB ERROR LOG will be printed when data from such a virtual output tray is printed.

■ Operations for Using a Barcode Reader

If an optional barcode reader (BC-1) is connected to the printer, it is possible to print data within a virtual output tray using the barcode in the list. Select the barcode for “Output (1)” in the upper right using the barcode reader and then select the barcode for the virtual output tray you want to print. If you want to delete the data in a tray, select “Delete (2)” also in the upper right and then select the barcode for the virtual output tray you want to delete. Note that all data in the tray will be deleted.

For detailed operating procedures for the barcode reader, please read the instructions included with the barcode reader.

Using the Printer

Memory Cards

This printer is equipped with a memory card slot. If a JEIDA Ver. 4.2 memory card is used, it is possible to read, write and delete data, and format the memory card.

Note:

Only 32 MB or less, flash or S-RAM type memory cards, conforming to JEIDA Ver. 4.2, can be written or formatted by this printer.

Font cards can be read from the control panel or read automatically upon power-on or printer reset when a font card is inserted in the printer.

■ Inserting a Memory Card

Carefully insert the memory card as far as it will go with the top (label) side facing as shown below.

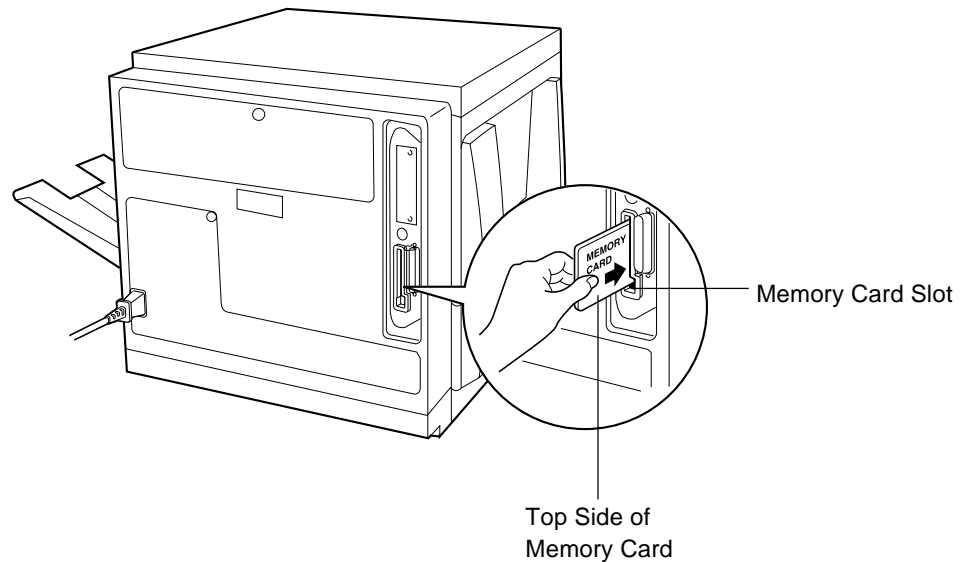

Notes:

Follow the precautions below when handling memory cards:

- Memory cards are sensitive to static electricity. Before handling a memory card, be sure to eliminate any static electricity which may have built up on your body or clothing by touching a metallic object.
- Use flash memory cards or S-RAM memory cards conforming to JEIDA Ver. 4.2 which are approved by Kyocera.
- Be sure that its power is off when inserting or removing a memory card.
- Do not insert memory cards into the slot with undue force.
- Do not bend memory cards.
- Do not drop memory cards or subject them to shock.
- Do not splash water or other liquids on memory cards.
- Do not place memory cards near fires or heat sources.
- Do not subject memory cards to direct sunlight.

Store memory cards in their protective case when not using them.

■ Reading Data from a Memory Card

The operation described here is performed while the message display reads `Ready`.

- 1** Insert the memory card into the memory card slot (☞ P. 57).
- 2** Bring up the menu `>Read font` on the message display.
For details on using the mode selection menu, see pages 37 and 44.
- 3** Press the **ENTER** key. The question mark (?) will appear and a data name will appear after it.
Press the **CANCEL** key to abandon reading data.
- 4** Press the **+** key to scroll through data names on the memory card.
- 5** Press the **ENTER** key again. This will cause `Processing` to appear in the message display and the selected data will be read.
- 6** After the data have been read, the message display will return to `Ready`.

■ Writing Data (Partitions) to a Memory Card

Up to 127 partitions can be written on a single memory card. Data written on the card are automatically assigned names, which can be checked by printing out a partition list. Check that the memory card is not write-protected.

- 1** Bring up the menu `>Write data` on the message display.
- 2** Press the **ENTER** key. `?` will appear.
- 3** Pressing the **ENTER** key again will cause `Processing` to appear in the message display followed by `Waiting`.
Press the **CANCEL** key to cancel writing data.
- 4** Send data from the computer to the printer.
[Example]
Sending the file `TEST.PRN` to the printer from the computer (DOS mode).

```
COPY TEST.PRN LPT1
```

The message display will change to `Processing` when data is received and will change back to `Waiting` when reception is finished.

Note:

A printable file should be stored on the memory card.

- 5 Check that the message display has changed to `Waiting` and press the **FORM FEED** key.

The printer will automatically print the data just written (example below). This printout can be used to check the name (partition name) under which data was written and confirm that it was written properly.

```

                                MEMORY CARD WRITE INFORMATION
-----
Slot number      : 4
Data type       : 2/Data
Partition name   : JAPAN003 /System define
Write data length : 00001704
Headers         :
```

Slot number: Slot name for the memory card (only A is supported)

Data type: Data type (only 2 is supported)

Partition name: Name of the partition (data) written

Write data length: Size of the partition data written (in units of bytes)

After printing is finished, the message display will return to `Ready`.

■ Deleting Data from a Memory Card

It is possible to delete data on a memory card one at a time. Check that the memory card is not write-protected.

- 1 Bring up the menu `>Delete data` on the message display. This display only appears if the memory card contains data.
- 2 Press the **ENTER** key. The question mark (?) will appear and a data name will appear after it.

The ? will flash, and a data name will appear.

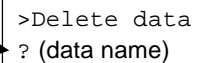

```
>Delete data
? (data name)
```

- 3 You can scroll through data names on the memory card one by one by pressing the **+** key.
Press the **CANCEL** key to cancel this operation.
- 4 Press **ENTER** key while the data you wish to delete is shown. The message display will change to `Processing`. Use this to check that the specified partition has been deleted properly.

■ Formatting a Memory Card

It is necessary to first format a new memory card before it can be used by the printer. Formatted memory cards can then be written with data.

Note:

- Note that if you format a memory card which already has data written on it, that data will be lost entirely.
- Check that the memory card is not write-protected.

- 1** Bring up the menu `>Format` on the message display.
- 2** Press the **ENTER** key. `?` will appear.
- 3** Pressing the **ENTER** key again will cause `Processing` to appear in the message display and the memory card will be formatted.

The printer will print memory card formatting information after initialization is finished. Use this to check that the memory card has been formatted properly.

After this information is printed, the message display will return to `Ready`.

■ Printing a List of Data Names (Partitions)

This operation prints the contents (data names, data size, etc.) of the memory card inserted in the memory card slot.

- 1** Bring up the menu `>List of Partitions` on the message display.
- 2** Press the **ENTER** key. `?` will appear.
Press the **CANCEL** key to cancel printing.
- 3** Press the **ENTER** key again. This will cause printing to start.
After this information is printed, the message display will return to `Ready`.

■ Memory Card Error Codes

Error codes 11, 13, 17, and 18 apply only to flash memory cards.

Error code	Meaning
MEMORYCARD err 01 Press CONTINUE	<ul style="list-style-type: none">You attempted to write more than 32 MB of data to a memory card. Or, the capacity of the memory card installed in the printer is more than 32 MB.A data name not existing on the memory card is specified. Check the data names on the memory card.
MEMORYCARD err 02 Press CONTINUE	<ul style="list-style-type: none">This memory card cannot be used by this printer.
MEMORYCARD err 03 Press CONTINUE	The memory card is not a JEIDA card. Only JEIDA Ver. 4.2 memory cards can be used by this printer.
MEMORYCARD err 04 Press CONTINUE	The card is an S-RAM or flash card which cannot be used by this printer.
MEMORYCARD err 05 Press CONTINUE	There is no battery in the memory card. Replace the battery in the memory card with a new one.
MEMORYCARD err 06 Press CONTINUE	The memory card is write-protected. Cancel the write-protection of the memory card.
MEMORYCARD err 07 Press CONTINUE	The memory card requires formatting. Format the memory card from the control panel (☞ P. 61).
MEMORYCARD err 09 Press CONTINUE	<p>The capacity of the memory card is insufficient. This error code appears when an attempt is made to write more data on the memory card than available memory. To halt the writing of data, first stop data transmissions from the computer, and then press the printer's CANCEL key.</p> <p>Press the FORM FEED key if the message <i>Waiting</i> will appear in the message display. The message display will return to <i>Ready</i>.</p>
MEMORYCARD err 11 Press CONTINUE	The memory card is full of data. The number of data which can be written on the memory card is limited to 127. Pressing the CANCEL key will restore the message <i>Ready</i> in the message display.
MEMORYCARD err 13 Press CONTINUE	This is a logical error. Try substituting another flash memory card.
MEMORYCARD err 17 Press CONTINUE	The flash memory card cannot be written due to insufficient printer memory. Either delete unnecessary macros and/or fonts stored in the printer, or expand the printer's available memory.
MEMORYCARD err 18 Press CONTINUE	This is a write error. Try substituting another flash memory card.

Setting the Sleep Timer

The sleep timer can be set anywhere from 0 to 120 minutes in 5-minute increments. Setting the sleep timer to 0 turns it off. The sleep timer is set at the factory to 60 minutes.

To set the sleep timer:

- 1** Press the **MODE** key on the printer panel.
- 2** Press the **+** key repeatedly until the message display indicates `Others>`.
- 3** Press the **▶** key.
- 4** Press the **+** key repeatedly until the message display indicates `>Sleep timer`.
The current sleep timer (in minutes) is indicated.
- 5** Press the **ENTER** key. The underline cursor flashes.
- 6** Press the **+** or **-** key to change the timer setting. You can use the **◀** or **▶** key to quickly change the timer setting.
- 7** Press the **ENTER** key to finalize the setting.
- 8** Press the **MODE** key to exit the mode selection menu.

Once the set time arrives, the printer will display `Sleeping` and all indicators will go out. This minimizes the amount of energy used.

Resource Protection

When you switch from the PCL 5C emulation to KPDL, all downloaded fonts and macros are lost. Resource protection preserves these PCL resources in memory so that they are intact when you change the emulation back to PCL 5C.

By using the printer's `>Resource prot.` menu, you can select from two resource protection modes:

Permanent

In this mode, the printer stores fonts, macros, symbol sets, etc. in memory that were downloaded as permanent PCL resources. All temporary resources are lost when the emulation mode is changed from PCL 5C to KPDL or vice versa.

Permanent and temporary

In this mode, the printer stores both permanent and temporary resources when the emulation mode is changed from PCL 5C to another or vice versa.

To select the resource protection mode:

- 1** Press the **MODE** key on the printer panel.
- 2** Press the **+** key repeatedly until the message display indicates `Others>`.
- 3** Press the **▶** key.
- 4** Press the **+** key repeatedly until the message display indicates `>Resource prot.`

The current resource protection mode is indicated — Permanent or Perm/Temp.

```
>Resource prot.  
Permanent
```

```
>Resource prot.  
Perm / Temp
```

- 5** Press the **ENTER** key. The question mark (?) will appear blinking.
- 6** Press the **+** key to change from Permanent to Perm/Temp, or vice versa.
- 7** Press the **ENTER** key to finalize the setting.
- 8** Press the **MODE** key to exit the mode selection menu.

Care and Maintenance

Cleaning

Periodic cleaning of the printer is recommended. The frequency of cleaning is dependent upon the environment in which the printer is used. You should clean the printer:

- At least once a month.
- When the printer experiences frequent media jams.
- When print quality has deteriorated.

■ External

- 1** Turn the power OFF.
- 2** Clean all the covers with a soft cloth. Use any mild commercial cleaner.

Caution:

Do not use benzine, thinner, aerosol cleaners, or any abrasive powder.

■ Internal

When using isopropyl alcohol with a lint-free cloth, make sure that the alcohol is at least 90% pure, obtainable from your local pharmacy. (Do not use rubbing alcohol; it can damage the printer.)

Cleaning the paper-pick rollers

- 1** Slide the media tray out (you do not have to remove it) to allow access to the paper-pick rollers.
- 2** Open the left side cover.

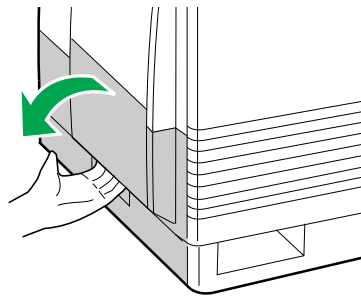

- 3** Use the green handles to pull out the paper feeder.

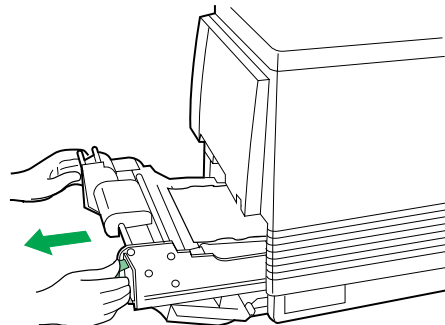

- 4 Gently rotate the paper-pick rollers 180° (the paper-pick rollers are D-shaped) and wipe them with a lint-free cloth that has been moistened with isopropyl alcohol.

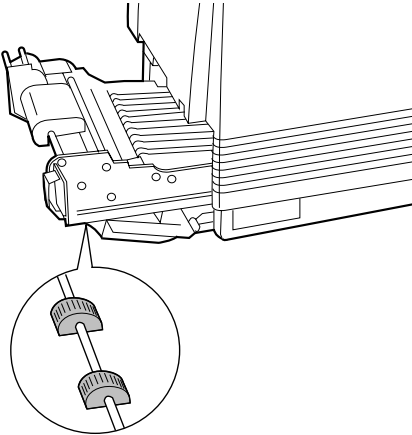

- 5 Reinsert the paper feeder (1) and close the left side cover (2).

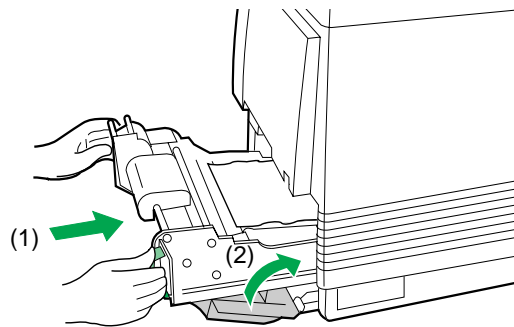

- 6 Slide the media tray back into place.

Cleaning the optional feeder and the duplex unit

If you have an optional paper feeder installed, you may also need to clean the rollers for the middle and lower media trays, which are accessed through the lower left side cover.

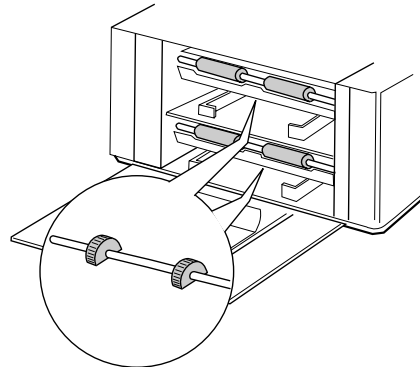

Care and Maintenance

When using the duplex unit, it may become necessary to clean the rollers inside the unit. Open the internal cover, and wipe the rollers with a lint-free cloth steeped in isopropyl alcohol.

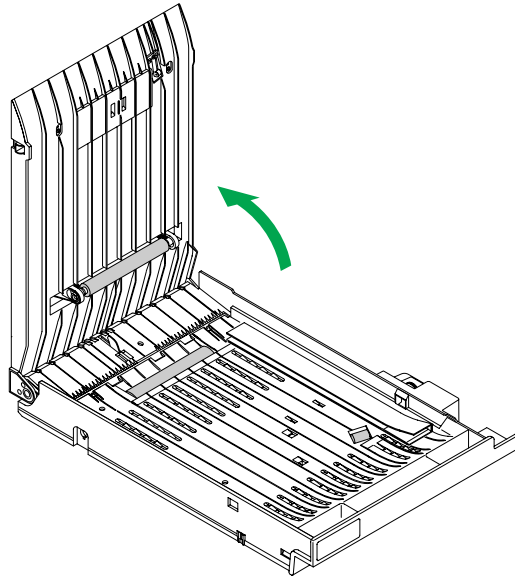

Cleaning the home sensor

- 1** Open the printer's front cover.
- 2** Remove the imaging unit:
 - (1) Loosen the two thumbscrews by turning them counterclockwise.
 - (2) Turn the lower green lever 180° counterclockwise.

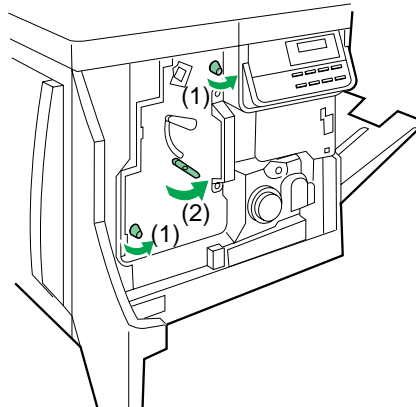

Care and Maintenance

- (3) Grasping the front green handle, slide the imaging unit out until it catches.
- (4) Lift up the left green handle. Pull the imaging unit out of the printer and cover it to protect it from light exposure.

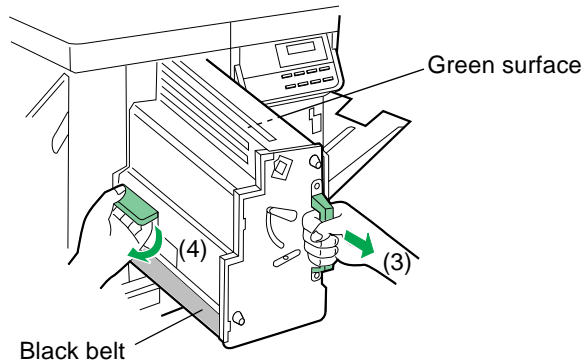

Important:

Do not touch the green surface (the right side) or the black belt (the underside). Finger prints may affect the print quality.

Safety Caution:

The imaging unit weighs approximately 6.5 kg (14.3 lbs.). Always use the handles when lifting it.

Cautions:

- Do not expose the imaging unit to artificial light for more than 45 seconds; or you may damage the unit. Never expose it to direct sunlight.
- Do not leave the printer's front cover open for an extended period of time (for example, several hours).

Care and Maintenance

- 3** Use a dry, lint-free cloth to wipe the slot of the sensor.

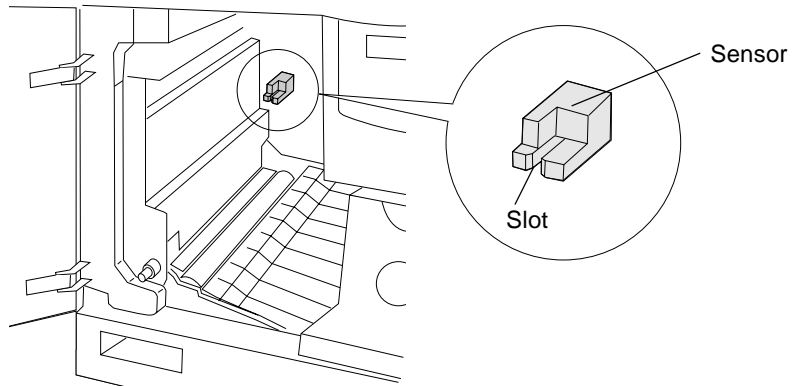

- 4** Reinsert the imaging unit into the printer, holding it by its green handles.

Match the arrow on the right side of the imaging unit with the arrow on the printer, and slightly push the imaging unit into the printer. Then release the left handle and push the unit in until it stops.

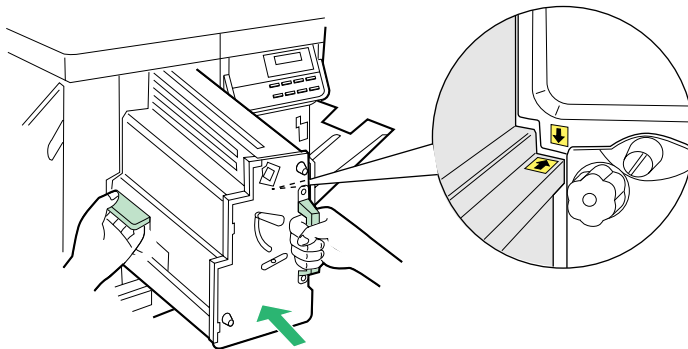

- 5** (1) Turn the lower green lever clockwise 180° to insert the unit completely and to lock it.
(2) Tighten the two green thumbscrews by turning them clockwise.
(3) Close the front cover.

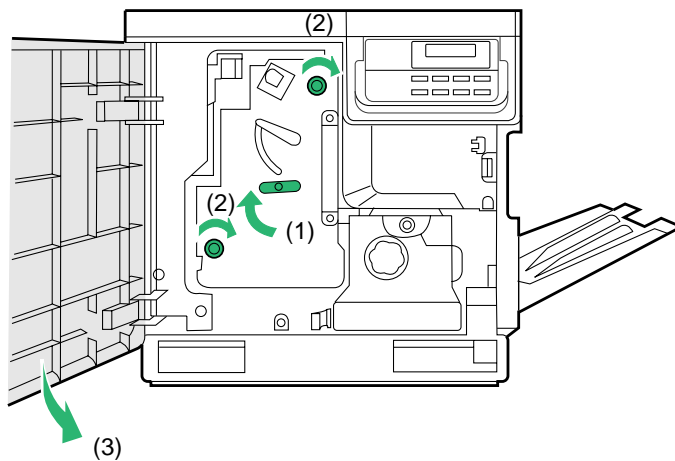

User Replaceable Components

When the printer panel indicates that a supply needs to be replaced, make sure that you have replacement supplies on hand. The printer may continue to print until the supply is completely used up; then it stops until you replace the indicated supply.

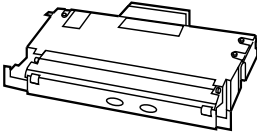
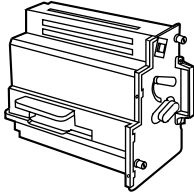
Toner Developers	Printer panel message	Average life ^{*1}
<p>Toner Developers</p> 	<p>Toner low TD-81x (Colour)</p> <p>Change the colour toner developer soon.</p>	<p>Black^{*2} 11,600 pages C, M, Y^{*2} 9,600 pages</p>
	<p>Replace Toner TD-81K (Black)</p> <p>Change the black toner developer now.</p>	<p>Black^{*2} 12,000 pages C, M, Y^{*2} 10,000 pages</p>
<p>Imaging Unit</p> 	<p>Warning IU-81 Imaging unit</p> <p>Change the Imaging unit soon.</p>	<p>Monochrome 57,000 pages or Colour 14,250 pages</p>
	<p>Replace IU-81 Imaging unit</p> <p>Change the Imaging unit now.</p>	<p>Monochrome 60,000 pages or Colour 15,000 pages</p>



^{*1}These figures are based on an average of 5% coverage of the printable area and standard density for any one colour. The frequency of replacement will vary depending on the complexity of the prints and the percentage of coverage and print density.

^{*2}The starter developers that are shipped with the printer have an average life of approximately 6,000 pages (Black), 5,000 pages (C, M, Y), based on an average of 5% coverage.

Note:

If you print with high density when Toner low is displayed, you may get faded printout before Replace Toner is displayed.

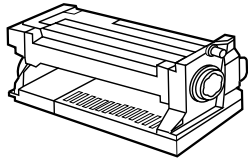
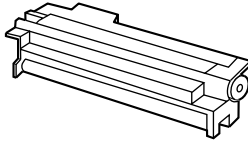
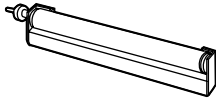
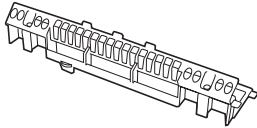
Care and Maintenance

Main Charger	Printer panel message	Average life
Fuser unit * (with pre-installed Oil Supply Roll and Cleaning Pad) 	Warning FK-81 Fuser KIT Fuser unit must soon be replaced.	57,000 pages
	Replace FK-81 Fuser KIT Fuser unit must now be replaced.	60,000 pages
Oil Supply Roll* (with pre-installed Cleaning Pad) 	Warning OS-81 Oil supply roll Oil Supply Roll and Cleaning Pad must soon be replaced.	14,500 pages
	Replace OS-81 Oil supply roll Oil Supply Roll and Cleaning Pad must now be replaced.	15,000 pages
Transfer unit 	Warning TR-81 Transfer roller Transfer unit must soon be replaced.	80,000 pages
Cleaning Pad 	Warning CP-81 Fuser clean pad Cleaning Pad must soon be replaced.	15,000 pages
Main Charger 	Warning MC-81 Main Charger Main Charger must soon be replaced.	Monochrome 30,000 pages or Colour 7,500 pages

* Transparencies, coated paper, and other specialty media will result in shortening the life of a consumable. When replacing the fuser unit, replace the oil supply roll as well. Do not insert the used oil supply roll into the new fuser unit.

Clearing a Jam

■ Clearing a media jam

Make sure that you follow these guidelines to avoid frequent media jams:

- Always use high-quality plain paper and transparencies. Refer to pages 111 and on.
- Make sure that you load specialty media only in the multi-purpose tray and that you set the media thickness switch to the correct setting for the media used.

If a media jam occurs, the printer panel reports “Paper Jam.” It is followed by one of the letters A through H that correspond to the various sensors throughout the paper path.

The following illustration shows the locations of the sensors that report media jams (A through H).

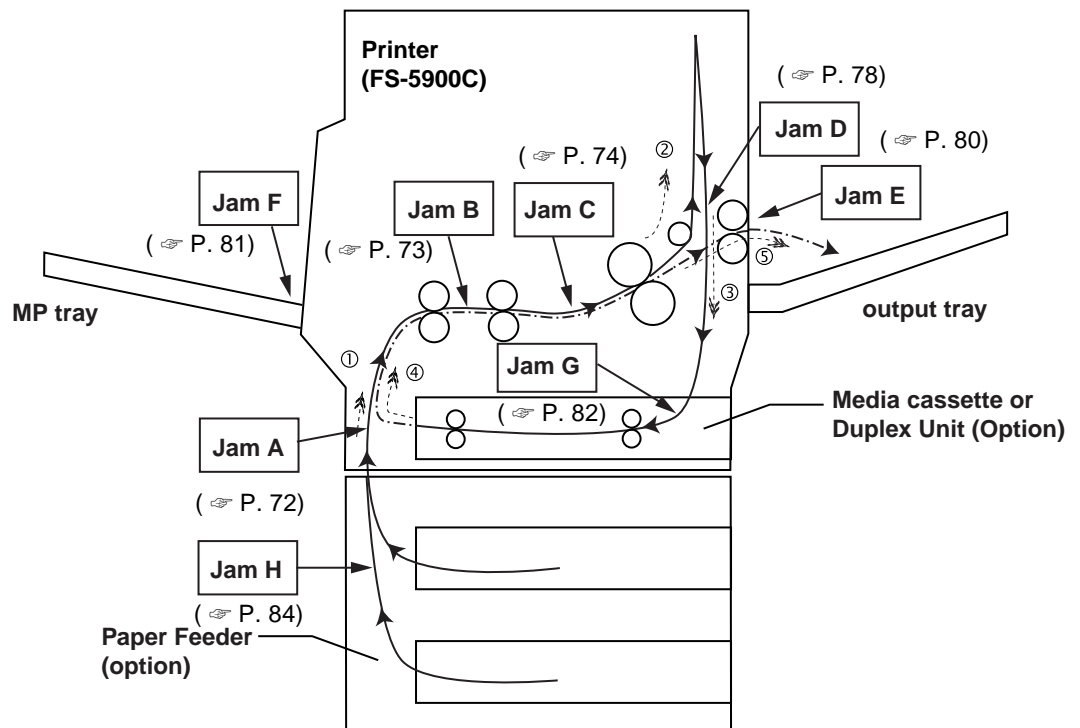

Notes:

- Sometimes the page on which the paper jam occurred will not be re-printed depending on the location of the paper jam.
- Note that your hands may become dirty from unfused toner when removing paper jams.

Frequent occurrence of paper jams may indicate you are using a paper specification which does not suit the printer. If this appears to be the case, please change to a different type of paper.

If you have tried changing paper types and paper jams still occur frequently, there may be a problem with the printer. In this case, please contact your Kyocera dealer.

Care and Maintenance

■ Jam at A

1 Open the left side cover corresponding to the selected media cassette.

2 Remove the jammed media.

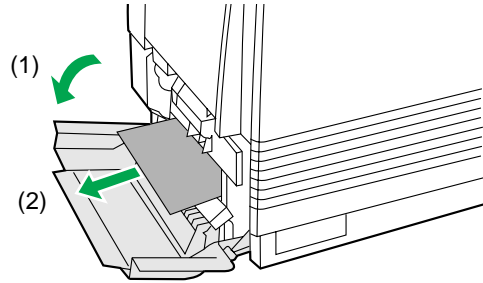

3 Close the left side cover.

— OR —

4 Remove the media cassette or duplex unit.

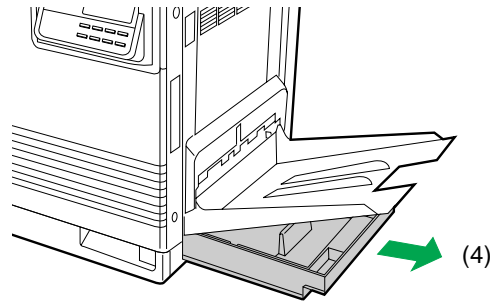

5 Remove the jammed media from inside the printer.

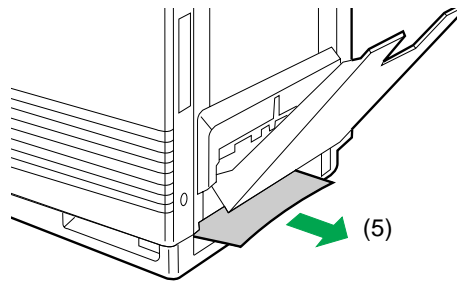

6 Reinsert the media cassette.

7 Open and close the front cover to clear the error message from the message display.

■ Jam at B

- 1 Open the left side cover.

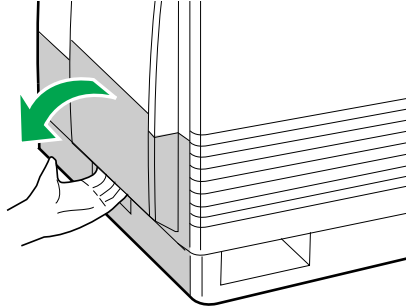

- 2 Use the green handles to pull out the paper feeder.

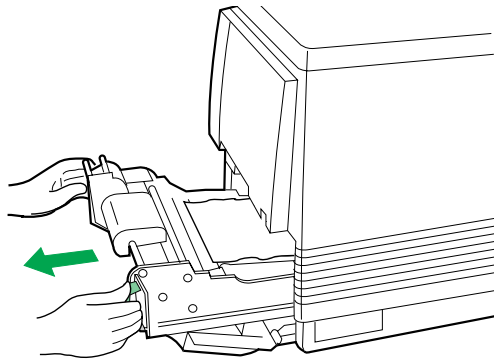

- 3 Remove the jammed media on the paper feeder.

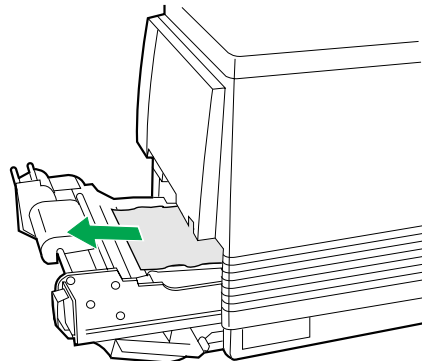

- 4 Reinsert the paper feeder and close the left side cover.

Care and Maintenance

■ Jam at C

1 Remove the fuser:

- (1) Open the printer front cover.
- (2) Turn the small green thumbscrew counterclockwise to unlock the fuser.

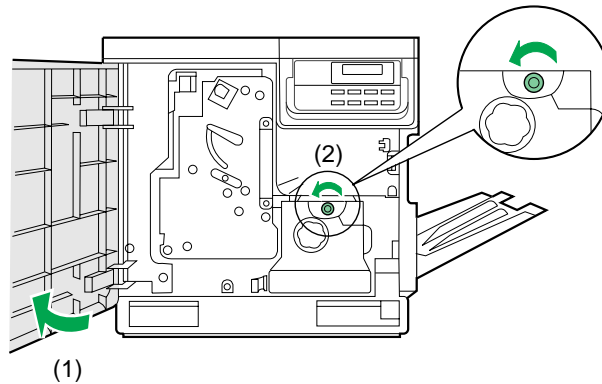

Safety Caution:

- The fuser is hot. To avoid personal injury, turn off the printer and wait 10 minutes (after opening the front cover) for the fuser to cool before touching it.

- (3) Holding the green tab on the right, slide the fuser out until the safety catch stops it.
- (4) Press the green lever on the left to release the safety catch.

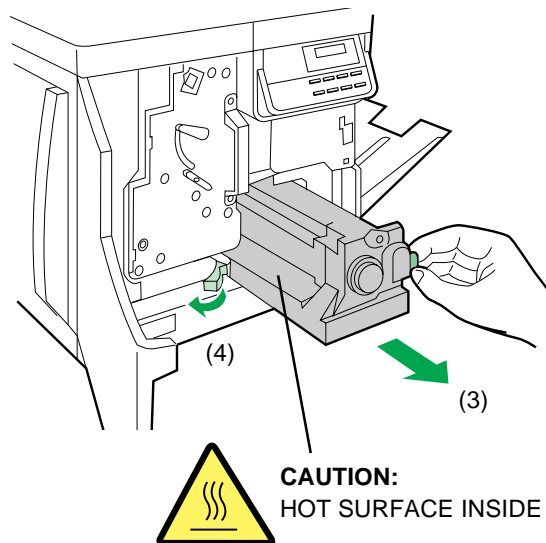

- 2** (1) Hold the fuser as shown below, and slide it out of the printer.

Safety Caution:

The fuser unit weighs approximately 3.1 kg (6.8 lbs.). Take care when handling it.

- (2) Close the front cover.

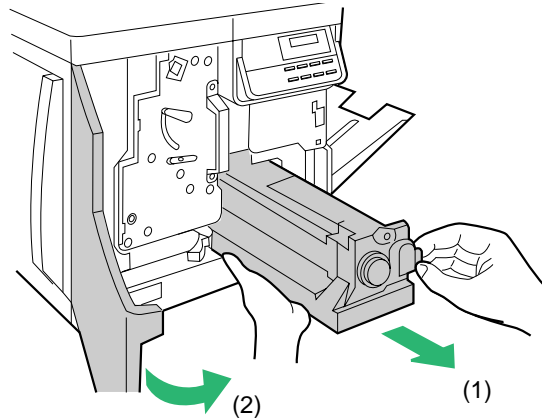

- 3** Remove the oil supply roll:

- (1) Press out on tabs to unlock the oil supply roll.

- (2) Remove the oil supply roll out of the fuser.

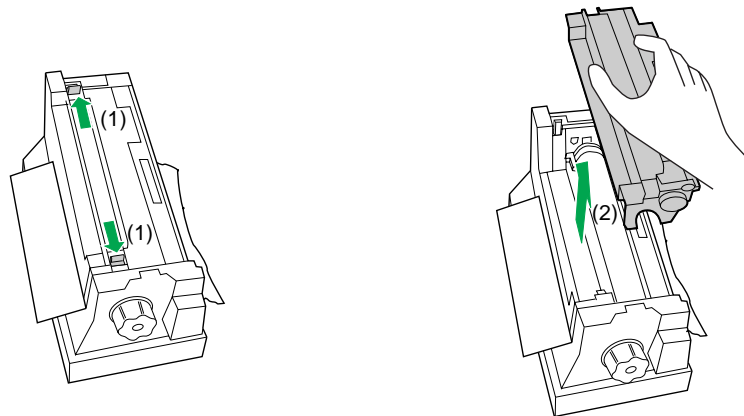

Note:

- Do not turn the green handle before removing the oil supply roll.
- If the paper is not jammed in the fuser unit, perform the following.

(1) Repeat steps 1 to 4 of Jam B on page 73.

(2) Skip step 4 and go to step 5.

Care and Maintenance

- 4** (1) Turn the fuser's large green knob clockwise.
(2) Remove the jammed media.

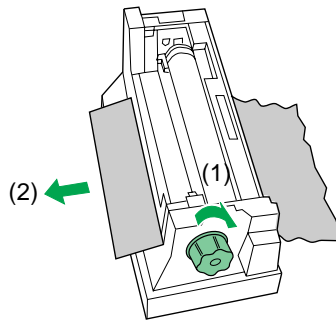

- 5** (1) Replace the oil supply roll into the fuser.
(2) Press down firmly on the oil supply roll to snap both sides into place.

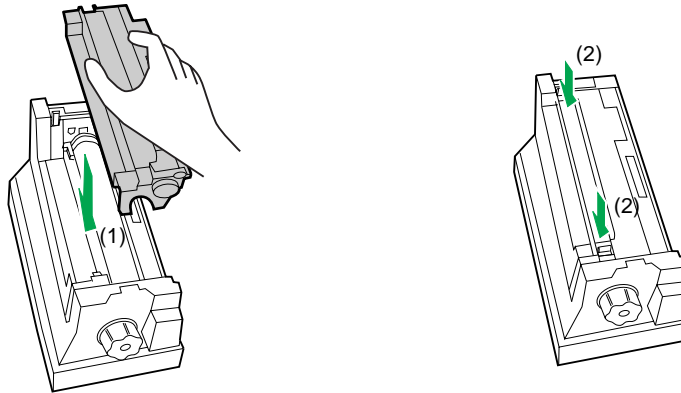

Caution:

If the oil supply roll is not installed correctly, print quality will be diminished.

- 6** (1) Open the front cover.
(2) Slide the fuser back into the printer.

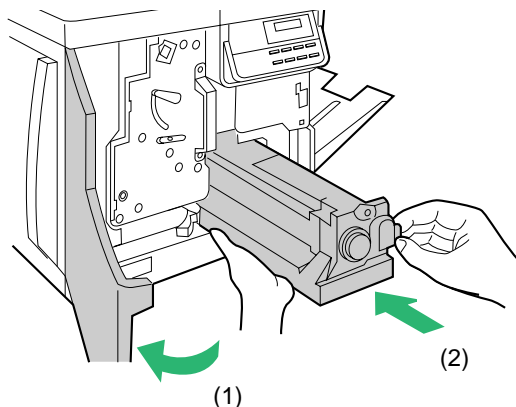

Care and Maintenance

- 7** (1) Turn the small green thumbscrew clockwise to lock the fuser.
(2) Close the front cover.

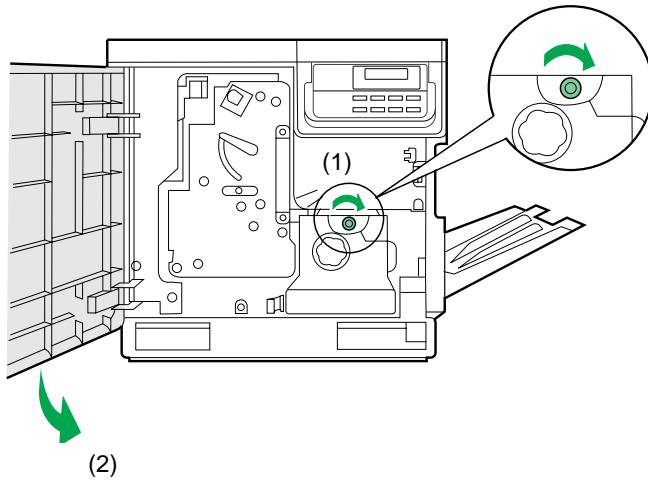

Care and Maintenance

■ Jam at D

Safety Caution:

The fuser is hot. To avoid personal injury, turn off the printer and wait 10 minutes (after opening the front cover) for the fuser to cool before touching it.

Note:

First check the exit opening for media that has jammed and folded like an accordion. It is especially difficult to see if the media is transparency film.

1A (Printing face up)

- (1) Open the front cover and the right side cover.
- (2) Turn the fuser's large green knob counterclockwise to release the jammed media.
- (3) Remove the jammed media from the right side of the printer.

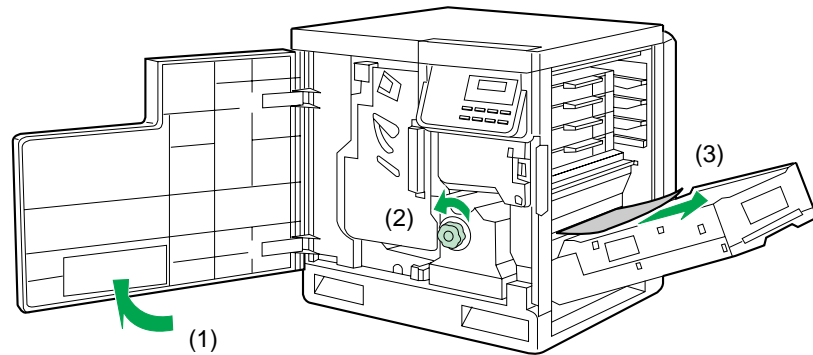

Safety Caution:

The fuser is hot. To avoid personal injury, turn off the printer and wait 10 minutes for the fuser to cool before touching it.

- (4) Close the front cover and the right side cover.

1B (Printing face down)

- (1) Open the front cover.
- (2) Pull open the access door (above the plastic output tray). See if the media is visible.

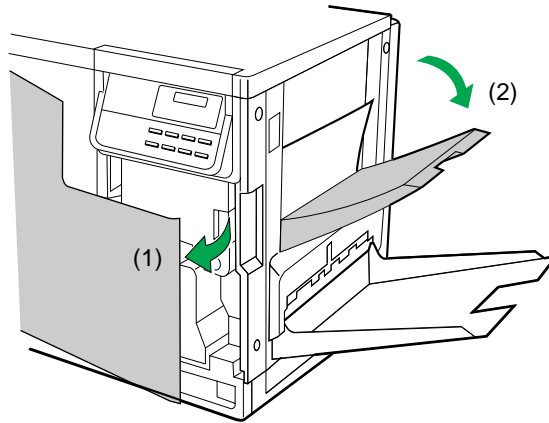

- (3) Turn the large green knob on the fuser counterclockwise.
- (4) Remove the media from inside the access door.

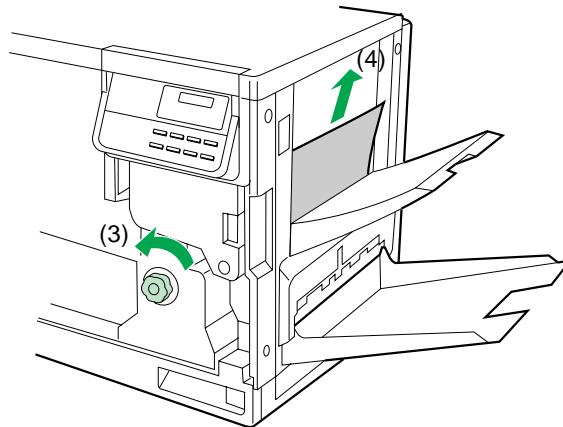

Caution:

If the fuser knob will not turn, do not force it, or you may damage the fuser. Instead, follow these steps:

- a) Unlock the fuser by turning the small green thumbscrew counterclockwise.
- b) Pull the fuser out. The media will probably tear.
- c) Remove the oil supply roll.
- d) Turn the fuser's large green knob to release the jammed media.
- e) Remove the jammed media from the fuser and the printer.

Safety Caution:

Be careful not to let go of the access door while it is opened.

- (5) Close the front cover.

Care and Maintenance

■ Jam at E

- 1 Remove the jammed media from the output tray.

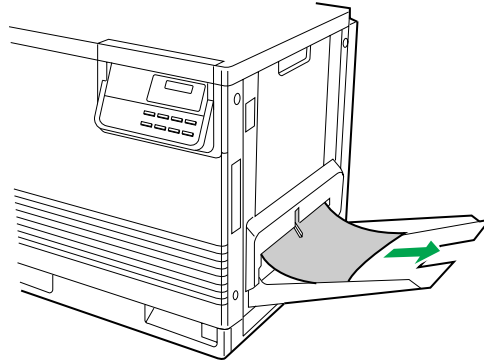

— OR —

Pull open the access door (above the plastic output tray) and remove the media.

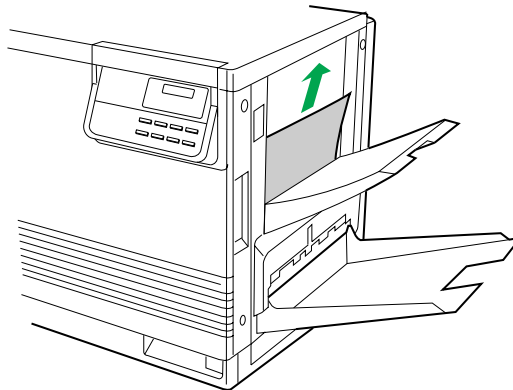

Safety Caution:

Be careful not to let go of the access door while it is opened.

— OR —

Open the cover on the right side, and remove the media.

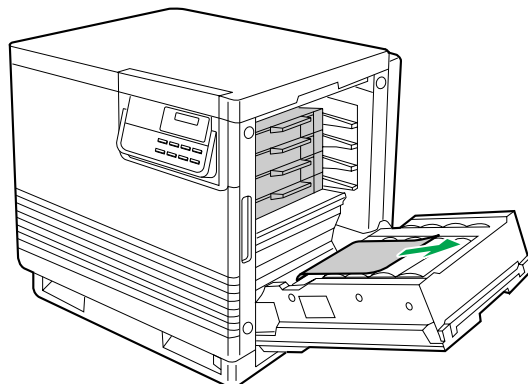

- 2 Open and close the front cover to clear the error message from the message display.

■ Jam at F

- 1** Remove the jammed media from the multi-purpose tray.

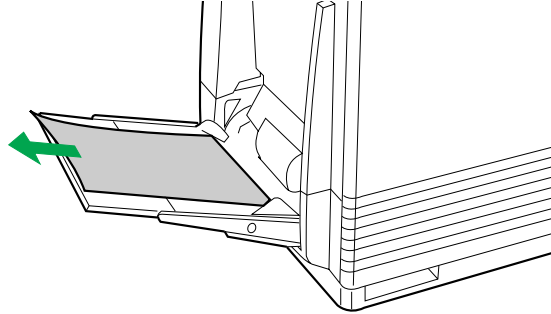

- 2** Open and close the front cover to clear the error message from the message display.

Care and Maintenance

■ Jam at G

- 1 (1) Pull open the access door (above the plastic output tray), and look for any paper.
(2) Remove the media from inside the access door.

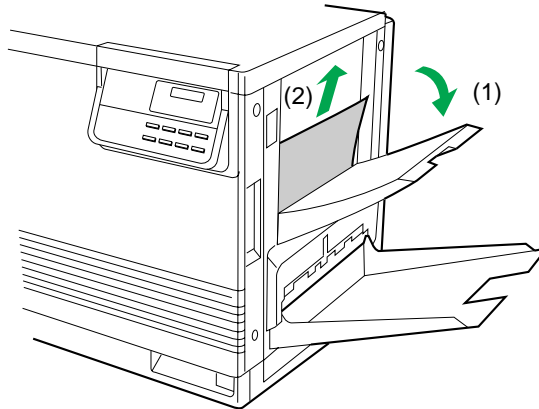

Safety Caution:

Be careful not to let go of the access door while it is opened.

— OR —

- (3) Remove the duplex unit.

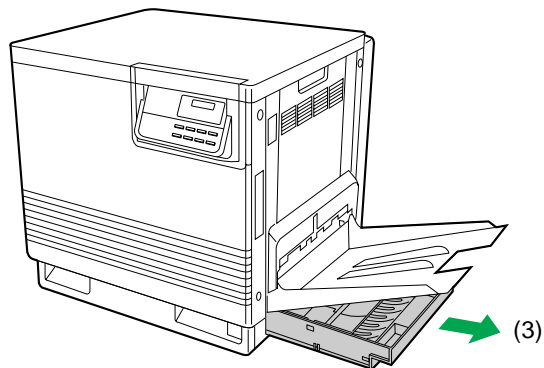

Care and Maintenance

(4) Remove the jammed media from the duplex unit.

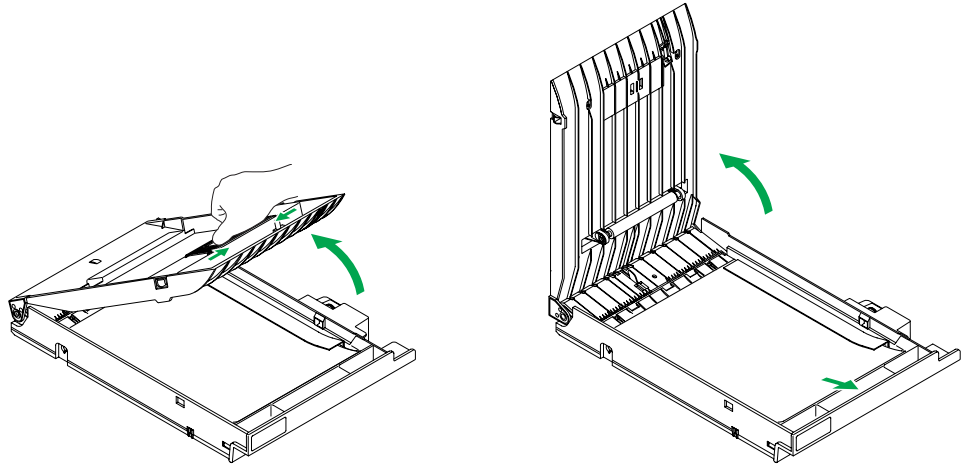

2 Open and close the front cover to clear the error message from the message display.

Care and Maintenance

■ Jam at H

- 1 Open the lower left side cover.

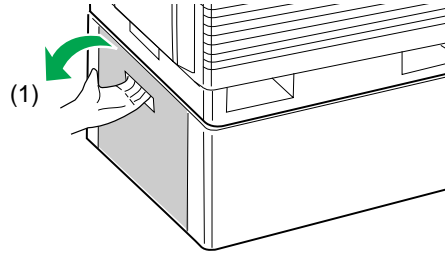

- 2 Remove the jammed media.

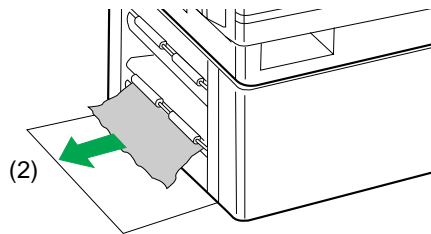

- 3 Close the lower left side cover.

— OR —

- 4 Remove the selected media cassette (middle or lower media tray).

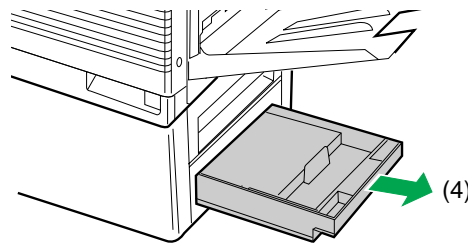

- 5 Remove the jammed media from inside the printer.

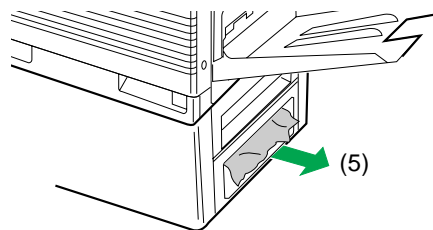



- 6 Reinsert the media tray.

- 7 Open and close the front cover to clear the error message from the message display.

Care and Maintenance

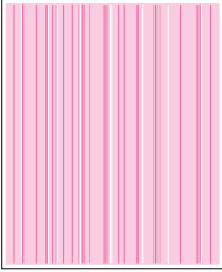
Troubleshooting

Trouble	Possible Cause	Corrective Action
<p>A single colour is not uniform or many vertical streaks (both light and dark) of slightly different density and non-uniform colour.</p> 	<p>The toner is almost depleted.</p>	<p>Replace the colour toner developer.</p>
<p>Half tone area has areas of weak colour.</p> 	<p>Paper doesn't match the environmental conditions, or it has too much moisture.</p>	<p>Try fresh paper, or another type of paper.</p>
<p>A single colour appears faded.</p>	<p>The colour density is set incorrectly in the printer panel.</p>	<p>Check the density setting by printing the Colour Calibration Page in the Colour Calibration menu from the printer panel. Compare the settings with the colour density samples on the Colour Calibration Reference and, if necessary, adjust the density from the printer panel. Refer to Setting the Colour Density on page 31.</p>
	<p>The toner is almost depleted.</p>	<p>Replace the colour toner developer soon (depending on the complexity of your prints, you can continue to print up to 100 more pages).</p>

Care and Maintenance

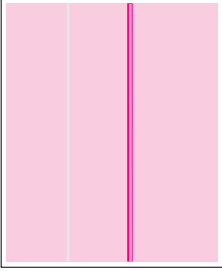
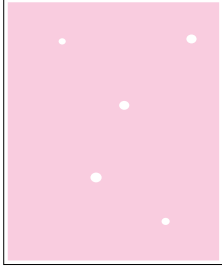
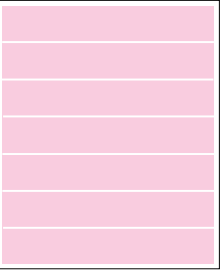
Trouble	Possible Cause	Corrective Action
<p>A single colour has a sharp, dark or light vertical streak.</p> 	<p>The toner developer is almost depleted and is not properly applying toner.</p>	<p>Replace the colour toner developer.</p>
<p>Small white spots appear on OHP transparency.</p> 	<p>OHP transparency has dust on its surface.</p>	<p>Remove dust or stain from OHP transparency.</p>
<p>A single colour shows a light, repeating horizontal line.</p> 	<p>The roller in the toner developer has a slight impression after a long period of storage.</p>	<p>Run 20-30 prints. The impression will disappear with continued time and use.</p>
<p>Prints are missing fine-line detail.</p>	<p>The imaging unit has reached its useful life.</p>	<p>Replace the imaging unit.</p>
<p>Dark colour spots and dark or light streaks appear in all colours.</p>	<p>The imaging unit has reached its useful life.</p>	<p>Replace the imaging unit.</p>

Care and Maintenance

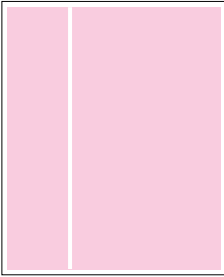
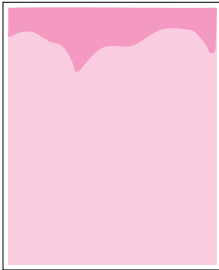
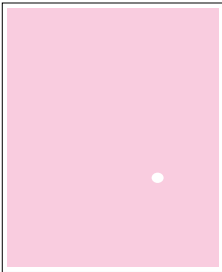
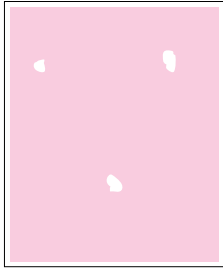
Trouble	Possible Cause	Corrective Action
<p>Straight, thin light vertical line in colours.</p> 	<p>The photosensitive belt inside the imaging unit is scratched.</p>	<p>Replace the imaging unit.</p>
<p>Each colour “bleeds” into the colour band.</p> 	<p>The imaging unit’s internal waste toner box is full.</p>	<p>Replace the imaging unit.</p>
<p>A single white spot appears in approximately the same vertical place on the page.</p> 	<p>The imaging unit is damaged.</p>	<p>Replace the imaging unit.</p>
<p>Large light spot(s) appear randomly.</p> 	<p>Fingerprint(s) on the underside belt or photosensitive belt (inside) of the imaging unit.</p>	<p>Print several pages until the spots fade.</p>

Care and Maintenance

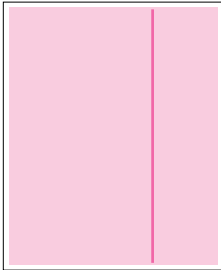
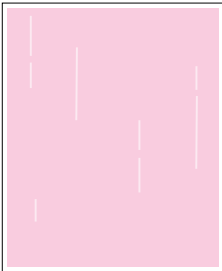
Trouble	Possible Cause	Corrective Action
<p>One or more dark vertical lines appear on the print in all colours.</p> 	<p>The imaging unit is scratched.</p>	<p>Replace the imaging unit; make sure that the old imaging unit is not exposed to light for more than 45 seconds.</p> <p>If a new imaging unit does not correct the problem:</p> <ul style="list-style-type: none"> • Put the old imaging unit back into the printer. • Repack the new imaging unit.
	<p>The fuser is damaged.</p>	<p>Replace the fuser.</p>
<p>A piece of the printed image is missing and reappears out of place, approximately 129 mm (5") down the page.</p>	<p>The fuser's internal roller is not being consistently oiled. or The fuser's internal roller is contaminated with toner particles</p>	<p>Print 5-10 pages of blank pages to clean the roller. If you still see the problem: Replace the oil supply roll. If you still see the problem: Replace the fuser.</p>
<p>The surface of the printed image appears to have vertical scratches (visible by holding the print at an angle and observing the "shine" of the image). At first, the scratches appear only on the printed image; eventually, dark vertical scratches appear on the unprinted portion of the page.</p>	<p>The fuser is near its useful life.</p>	<p>Replace the fuser (depending on your quality needs, you can continue to print until the dark vertical lines appear).</p>
<p>Media frequently wraps around the fuser.</p>	<p>The oil supply roll has reached its useful life.</p>	<p>Replace the oil supply roll.</p>
<p>Light vertical streaks appear in all colours.</p> 	<p>The main charge grid is dirty.</p>	<p>Replace the imaging unit.</p>

Care and Maintenance

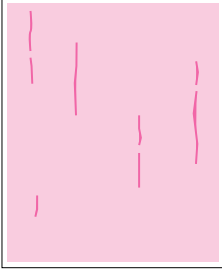
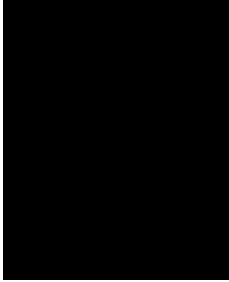
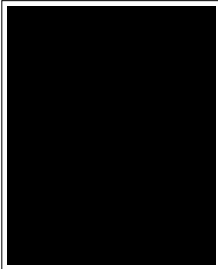
Trouble	Possible Cause	Corrective Action
<p>Dark and wavy vertical streaks appear in all colours.</p> 	<p>The main charge grid is dirty.</p>	<p>Replace the imaging unit.</p>
<p>The entire page prints in black, including the borders.</p> 	<p>Bad electrical contact for the main charge grid.</p>	<p>Reinsert the imaging unit to correct the contact for the main charge grid.</p>
	<p>The main charge grid is broken.</p>	<p>Replace the imaging unit.</p>
<p>Toner spots appear on the back of the media.</p>	<p>The transfer unit is worn out.</p>	<p>Replace the transfer unit.</p>
<p>The page prints in black in the image area only. (The borders are clear.)</p> 	<p>Either the image processor board or engine control board is not functioning properly.</p>	<p>Turn the printer off and back on again. If the problem persists, call for service on your printer.</p>

Care and Maintenance

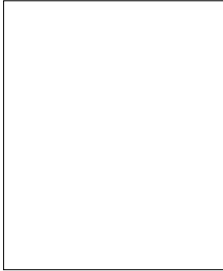
Trouble	Possible Cause	Corrective Action
<p>The page is completely blank.</p> 	<p>The problem could be with one of the following:</p> <ul style="list-style-type: none"> • Engine control board. • Developer voltage. • Laser scanning unit mirror. 	<p>Turn the printer off and back on again. If the problem persists, call for service on your printer.</p>
<p>“Call service person ...” is displayed on the message display.</p>	<p>An error occurred that is not user-correctable.</p>	<p>Turn the printer off and back on again. If the error persists, call for service.</p>

■ If you can't make a print

Trouble	Possible Cause
<p>The printer does not operate.</p>	<p>Make sure that you plugged in the printer and turned it on.</p>
	<p>Make sure that you connected the interface cable(s) properly.</p>
<p>The printer does not print.</p>	<p>If the communication link between your computer and the printer is working but the printer ejects a blank page when printing from your application or through Windows, make sure that the appropriate driver is installed and that you have selected the printer correctly.</p>

Trouble	Possible Cause	Corrective Action
<p>The printer does not print correctly.</p>	<p>The computer is not properly communicating with the printer.</p>	<p>Follow the procedure below and disable the bi-directional interface.</p> <p>Under Windows 95/98:</p> <ol style="list-style-type: none"> 1. Click Start, select Settings, then click Printers. 2. Double click the Kyocera FS-5900C icon. 3. Click the Printer menu, then click Properties. 4. Click the Details tab and Spool settings... 5. Click Disable bi-directional support for this printer, then click OK.

■ Media problems

Trouble	Possible Cause
Frequent paper-picking errors	Fan the paper or transparencies before installing them in their respective cassettes; this is especially important for transparencies because they tend to stick together.
	Make sure that you have loaded paper in the paper tray and transparencies in the transparency cassette.
	Make sure that the media is installed under the hooks at the front of the media cassette.
	If printing on transparencies and your printer has an option Paper Feeder, make sure that the transparency cassette is installed in the upper or middle tray slot.
	Clean the paper-pick rollers (☞P. 64).
Frequent media jams	Make sure that you use a high-quality laser paper: 60-105 g/m ² (16-28 lbs.) paper in the media cassettes and 75-165 g/m ² (20-44 lbs.) paper in the multi-purpose tray.
	If you are using media that is 105 g/m ² (28 lbs.), check if the Face Down media output setting is selected in the driver. If it is, change the setting to Face Up.
	Use only recommended transparencies (☞P. 114). We cannot guarantee the results of using other transparencies.
	Make sure that the media is installed under the hooks at the front of the media cassette.
	Do not overfill the media cassette, as indicated by the red line on the right side of the cassette.
	Clean the paper-pick rollers (☞P. 64).
	Make sure that the media thickness switch is set correctly for the installed media (☞P. 19).

■ Problems with image size and position

Trouble	Possible Cause
Off-set images	Check your application for correct image sizing.
Cut-off images	Check your application for image sizing.
	Make sure that the correct size media is in the media cassette.

Care and Maintenance

■ Print quality problems

Trouble	Corrective Action
Prints have dull, faded colours.	Print the Colour Calibration Page from the Colour Calibration menu in the printer panel. Check the density settings for each colour and compare them to the examples on the Colour Calibration Reference card. Refer to Setting the Colour Density on page 30 for instructions on comparing and setting colour density.
	Make sure that the imaging unit stays covered until immediately before installing it in the printer. Exposure to light can damage the imaging unit and will produce light streaks or faded prints.
	Make sure that the toner developers are installed correctly.
	Make sure that you use a high-quality laser paper: 60-105 g/m ² (16-28 lbs.) paper in the media cassettes and 75-165 g/m ² (20-44 lbs.) paper in the multi-purpose tray.
Image is very faded or pieces of the image are missing; toner on the page is loose.	When using the multi-purpose tray, make sure that you have selected the correct media type in the driver or in the MODE menu of the operation panel.
Streaks or spots	Most spots are caused by fingerprints or dust introduced into the printer while installing the imaging unit or loading media.
	Make sure that the surface where you unpack the imaging unit, paper, and transparencies is free of dust. Keep supplies in a covered area or a closed box.
	Make sure that the imaging unit stays covered until immediately before installing it in the printer. Exposure to light for more than 45 seconds can damage the imaging unit.
	Do not touch the right side or underside of the imaging unit; fingerprints affect print quality.
	Make sure that the paper or transparency film is clean.
	Make sure that you handle the media on the outside edges to avoid fingerprints.
	To get rid of fingerprint spots, print a few prints.
The back of the printed page appears dirty.	Toner particles have contaminated the transfer roller. This can happen if the printed image is larger than the media (for example, when printing on envelopes). Run 10-20 prints to clean the transfer roller.
The print quality of a transparency is poor.	There is a defect on the coated surface of the transparency. Print on the other side.

Care and Maintenance

Error Messages

Printer Panel Message

Error Message	Possible Cause	Corrective Action
Add paper (<i>paper source</i>) (<i>paper size</i>)(<i>media type</i>)	The paper source is out of paper.	Add paper to the paper cassette or multi-purpose tray. Not only the paper source, but also the paper size and media type set for the paper source in question are displayed.
Battery error MEMORY CARD	The memory card's battery is run out or not installed.	Insert a new battery in the memory card. (See the memory card manufacturer's instruction.)
Call service person##:#####	A failure requiring the attention of service personnel has occurred.	Note the corresponding error code (## followed by the colon) and the total printed pages ¹ (##### preceded by the colon). Turn printer power off and call for service.
Cassette 1 not loaded	The printer's media cassette is not loaded in the printer, or not closed fully in position.	Insert the media tray, or close it securely. (Cassette 1 is shown as Cassette when no option paper feeder is installed.)
Cassette 2 not loaded	The paper feeder's top media cassette is not loaded in the paper feeder, or not closed fully in position.	Insert the top media tray, or close it securely. (This message is shown only when the printer is installed with an option paper feeder.)
Cassette 3 not loaded	The paper feeder's bottom media cassette is not loaded in the paper feeder, or not closed fully in position.	Insert the bottom media tray, or close it securely. (This message is shown only when the printer is installed with an option paper feeder.)
Duplex unit not loaded	The Duplex unit is not installed in the printer.	Install the Duplex unit in the printer.
Format error (Media)	The hard disk or memory card is not formatted.	Format the media (For a memory card, see P. 60).
Front/Right cover Open	The front or right side cover is open.	Check both covers and close them tightly.
HARDDISK error## Press CONTINUE	The printer has encountered an error during access to the optional hard disk.	Note the error code (##) preceded by the HARDDISK error message. Then, press CONTINUE to clear the error situation. Refer to section Hard disk Error Codes (see P. 99).

¹ The total printed pages is not shown when the error code is F0 (Communication error).

Care and Maintenance

Error Message	Possible Cause	Corrective Action
I/F occupied	The front control panel operation you attempted is not possible because that interface is receiving data.	Wait until the data transfer is completed on that interface.
Imaging unit not locked	The imaging unit is not locked properly because its lever is not lifted.	Lift the imaging unit lever fully up.
Insert the same MEMORY CARD	A different memory card was inserted following the MEMORY CARD err/ Insert again message.	Reinsert the same memory card as was removed previously into the printer's memory card slot.
KPDLE Error ## Press CONTINUE	The printer encountered an error during processing data in KPDLE mode.	Note the error code of ## and press CONTINUE to clear the error situation. See section KPDLE Error Codes (P. 100) for information.
Left cover Open	The left side cover is open.	Close it tightly.
Load (paper source) (paper size)(media type)	The paper size or type does not match the printing area.	One of MP tray, Cassette 1 to 3, will be displayed in place of "paper source". Load the paper displayed on the message display and press the CONTINUE key to print. Or, pressing the FEED key without pressing the CONTINUE key, will cause Use alternative? to be displayed, and a different paper source can be selected to supply paper. The paper source changes each time the FEED key is pressed. And press the MODE key to display Paper handling>. Press the ▶ key and you can change the paper source setting using the + or - key to select. Load paper appropriate for the paper source and press the EXIT key to print.

Care and Maintenance

Error Message	Possible Cause	Corrective Action
Load cassette # (paper size) (media type)	The paper size does not match.	The size of paper panel in the cassette is different to the size specified by the application software or by PRESCRIBE 2e command. Put paper of the specified size into the cassette. (# represents the cassette number) If the CONTINUE key is pressed, printing will be resumed. However, if more than one sheet is to be printed, the same message will again be displayed from the second sheet onward. You can abandon printing by pressing the CANCEL key.
MEMORYCARD err## Press CONTINUE	The printer has encountered an error during access to the memory card.	Look at the error code of ## preceded by MEMORYCARD err. Then, press CONTINUE to clear the error situation. Refer to section Memory card errors (☞ P. 61).
MEMORY CARD err Insert again	The memory card was removed during the memory card operation.	Re-insert the same memory card into the printer's memory card slot. The printer will continue with the memory card operation.
Memory overflow Press CONTINUE	The print data from the computer is larger than the printer can fit in its memory.	Press CONTINUE to print the data. Install additional memory .
Missing FK-81 Fuser KIT	The fuser kit is not installed in the printer.	Install the fuser kit.
Missing IU-81 Imaging unit	The imaging unit is not installed in the printer.	Install the imaging unit (☞ P. 68).
Missing MC-81 Main Charger	The Main Charger unit is not installed in the printer.	Install the Main Charger unit in the imaging unit.
Missing OS-81 Oil supply roll	The oil supply roller is not installed in the printer.	Install the oil supply roller (☞ P. 76).
Missing Toner TD-81C (Cyan)	The cyan toner developer is not installed in the printer.	Install the cyan toner developer (☞ P. 14).
Missing Toner TD-81K (Black)	The black toner developer is not installed in the printer.	Install the black toner developer (☞ P. 14).
Missing Toner TD-81M (Magenta)	The magenta toner developer is not installed in the printer.	Install the magenta toner developer (☞ P. 14).

Care and Maintenance

Error Message	Possible Cause	Corrective Action
Missing Toner TD-81Y (Yellow)	The yellow toner developer is not installed in the printer.	Install the yellow toner developer (☞P. 14).
Missing paper feed unit	The paper feeder unit is not installed in the printer.	Install the paper feeder unit.
Option feeder Left cover Open	The paper feeder's left side cover is open.	Close it tightly.
Opt. ROM error Press CONTINUE	The printer has encountered an error while accessing data in the option EPROM (on the printer main board).	Press CONTINUE to print the data processed so far. Replace the option EPROM.
Option interface Error ##	The printer has detected an error on the option interface.	Note the error code of ## and consult your Kyocera dealer.
Output tray paper full	The output tray has become full.	Remove paper from the output tray.
PJL OPMSG/STMSG	The printer encountered an error during processing PJJ commands.	Press CONTINUE to print the page processed so far.
Paper jam (Location)	Paper has become jammed.	Remove jammed paper according to section Removing Paper Jam (☞P. 71).
Print overrun Press CONTINUE	The printer has received print data that is too complex to finish processing in time with the operation of the printer mechanism.	Press CONTINUE to print the data. Install additional memory .
Processing PAR FIT A4	Compressed data is printed due to insufficient memory when FIT flashes in the resolution indicator. The quality of printed data is reduced when this occurs. Fit will continue flashing even after printing is finished. The resolution indicator will automatically return to the previous resolution when any key is pressed, when a timeout occurs, or when subsequent data is received.	Increase the printer memory to avoid this error.

Care and Maintenance

Error Message	Possible Cause	Corrective Action
<p>RAM DISK error ## Press CONTINUE</p>	<p>Check the error code displayed in the place of ## and refer to the corresponding description at right.</p>	<p>01: Abnormal format. Try turning the power off and on again. 02: RAM DISK mode is OFF. Turn RAM DISK mode On. 03: Cannot write to the disk system because it is write protected. Remove the write protection. 04: No disk space. Clean up files. 05: Specified file not on disk. 06: No memory for use by disk system. Expand printer memory. 10: Cannot format disk because host data is spooled there. Format the disk after Ready is displayed. 85: VMB: Alias error (Alias setting failure or no virtual bin corresponds to the alias.) Make the setting again. 86: VMB: Password error (No password specification, mistaken password, or password setting failure.) Check the password. 87: VMB: Although an attempt was made to use a virtual bin job stack, the stack size reached the maximum limit. Output the job or raise the maximum limit. 88: VMB: There was a job or page which could not be read out during virtual bin job output (the job is destroyed). 89: VMB: No job in the virtual bin specified for output or that virtual bin is not being used. Check the bin. 97: MPS: A non-volatile job has reached the maximum limit and no more data can be saved. Clean up the job or raise the maximum limit. 98: MPS: There was a page which could not be read out within a job (the job is destroyed).</p>

Care and Maintenance

Error Message	Possible Cause	Corrective Action
RAM DISK error ## Press CONTINUE		99: MPS: No job in the virtual bin specified for output or that page is missing.
Read font ? Failed	A font could not be read due to insufficient memory.	A download font could not be loaded into printer memory due to insufficient available printer memory. Either remove unnecessary download fonts or expand printer memory.
Read macro ? Failed	A macro could not be read due to insufficient memory.	A download macro could not be loaded into printer memory due to insufficient available printer memory. Either remove unnecessary download macro or expand printer memory.
Replace FK-81 Fuser KIT	The fuser is worn out.	Replace the fuser kit now.
Replace IU-81 Imaging unit	The imaging unit is worn out.	Replace the imaging unit now.
Replace OS-81 Oil supply roll	The oil supply roller is worn out.	Replace the oil supply roller now.
Replace Toner TD-81C (Cyan)	The cyan toner developer is empty.	Replace the cyan toner developer now.
Replace Toner TD-81K (Black)	The black toner developer is empty.	Replace the black toner developer now.
Replace Toner TD-81M (Magenta)	The magenta toner developer is empty.	Replace the magenta toner developer now
Replace Toner TD-81Y (Yellow)	The yellow toner developer is empty.	Replace the yellow toner developer now.
Reset Fuser cln. pad Press ENTER	The printer is waiting for your input confirming that you have replaced the Cleaning Pad and resetting its counter (☞ P. 45).	Press ENTER and the printer resets the transfer unit counter to 0000000. If you have not replaced the Cleaning Pad, press EXIT, to prevent the counter from being reset.
Reset Trans.Roll Press ENTER	The printer is waiting for your input confirming that you have replaced the transfer roller and resetting its counter (☞ P. 45).	Press ENTER and the printer resets the transfer unit counter to 0000000. If you have not replaced the transfer roller, press EXIT, to prevent the counter from being reset.
Set paper Press CONTINUE	The multi-purpose tray is empty.	Add a sheet of paper to the multi-purpose tray, and press CONTINUE key.

Care and Maintenance

Error Message	Possible Cause	Corrective Action
Toner low TD-81C (Cyan)	The cyan toner developer is almost empty.	Replace the cyan toner developer as soon as possible.
Toner low TD-81K (Black)	The black toner developer is almost empty.	Replace the black toner developer as soon as possible.
Toner low TD-81M (Magenta)	The magenta toner developer is almost empty.	Replace the magenta toner developer as soon as possible.
Toner low TD-81Y (Yellow)	The yellow toner developer is almost empty.	Replace the yellow toner developer as soon as possible.
Virtual Mail Box full	The virtual mail box area is full.	Print out accumulated VMB data. If the VMB function is being implemented by RAM DISK, increase the RAM DISK size.
Warning CP-81 Fuser clean pad	The Cleaning Pad is wearing out.	Replace the Cleaning Pad as soon as possible.
Warning MC-81 Main Charger	The Main charger is wearing out.	Replace the Main charger as soon as possible.
Warning FK-81 Fuser KIT	The fuser kit is wearing out.	Replace the fuser kit as soon as possible.
Warning IU-81 Imaging unit	The imaging unit is wearing out.	Replace the imaging unit as soon as possible.
Warning OS-81 Oil supply roll	The oil supply roll is wearing out.	Replace the oil supply roll as soon as possible.
Warning TR-81 Transfer roller	The transfer roller is wearing out.	Replace the transfer roller as soon as possible.
Warning battery MEMORY CARD	The memory card's battery is running out.	Change the memory card battery as soon as possible. (See the memory card manufacturer's instruction.)
Warning Low memory	The printer's internal memory is insufficient to complete the printing.	Press CONTINUE key to print the page processed so far. Remove any unnecessary fonts or macros in the printer or install additional memory.

■ Hard Disk Error Codes

Error Message	Remedy
HARDDISK error## Press CONTINUE	<p>Check the error code (digits) shown at the ## position, and refer to the following.</p> <p>01: Format error. The hard disk has malfunctioned. Turn on the printer again.</p> <p>02: No hard disk installed. Check whether the hard disk has been correctly installed.</p> <p>04: Insufficient capacity on hard disk, or the number of stored files has exceeded 10,000. Free disk space before attempting the operation again. Reduce the number of files on the hard disk.</p> <p>05: The specified file does not exist. Check whether a file with the specified name exists on the hard disk.</p> <p>06: The memory available for use by the file system is insufficient.</p>

■ KPDL Error Codes

Code	Error	Meaning
00	—	Cannot initiate KPDL
01	dictfull	Dictionary full; no new entries can be added
02	dictstackoverflow	Too many begins
03	dictstackunderflow	Too many ends
04	execstackoverflow	Execution stack nesting depth exceeded 250
05	handle	Name of error-reporting procedure
06	interrupt	Control-C was received
07	invalidaccess	Attempted violation of access attribute
08	invalidexit	Exit not enclosed in any loop
09	invalidfile	Invalid access string for file operator
10	invalidfont	Invalid font name or invalid font dictionary format
11	invalidrestore	Restore would destroy composite object created after save
12	ioerror	Input/output error
13	limitcheck	Path too complex, more than 6 files open, etc.
14	nocurrentpoint	No current point is defined
15	rangecheck	Operand out of allowed range
16	stackoverflow	Operand stack overflow
17	stackunderflow	Operand stack underflow
18	syntaxerror	Syntax error in program
19	timeout	Time limit exceeded
20	typecheck	Wrong type of operand
21	undefined	Name not found in dictionary
22	undefinedfilename	File cannot be found
23	undefinedresult	Overflow, underflow, or meaningless result

Code	Error	Meaning
24	unmatchedmark	Expected mark not found on stack
25	unregister	Internal error
26	vmerror	Virtual memory is exhausted, or illegal access was attempted
27	badpassword	Bad password
28	invalidnumber	Invalid number
29	nomemory	Memory unavailable
30	configurationerror	<i>Setpagedevice</i> request cannot be satisfied
31	invalidcontext	Improper use of context operation
32	invalidid	Invalid identifier for external object
33	undefinedresource	Resource instance not found
98	fatal	Fatal error (User memory exhausted)

Repacking

It is highly recommended that you keep the original carton and all packing materials. Should you need to transport or ship your printer, please follow these instructions.

Safety Caution:

The printer weights about 51 kg (112.4 lbs.). It must be handled by two people.

Notes:

- Should you need to send your printer for service, consult your reseller first or Kyocera.
- Please use the original carton and all of the original packing materials.
- If you do not have the packing for the imaging unit and the transfer unit: contact Kyocera for packaging.
- Improper repacking of the printer may result in a service charge to remove spilled toner.
- Since the printer uses dry toner, extreme care must be taken when handling. The printer should be handled in the upright (vertical) position.

Material required:

- Original cartons and packing materials
- Newspaper or drop cloth
- Shipping tape and scissors

Care and Maintenance

- 1** Turn off the printer; remove the power cord and all interface cables.
- 2** Remove the media cassette from the printer; remove the media from the cassette(s).

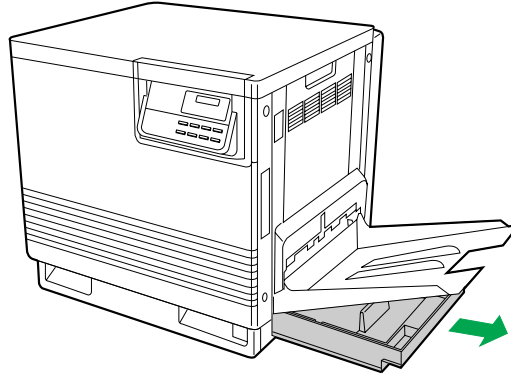

- 3** Press down on a media cassette's metal plate. Place the base plate stopper into the media cassette.

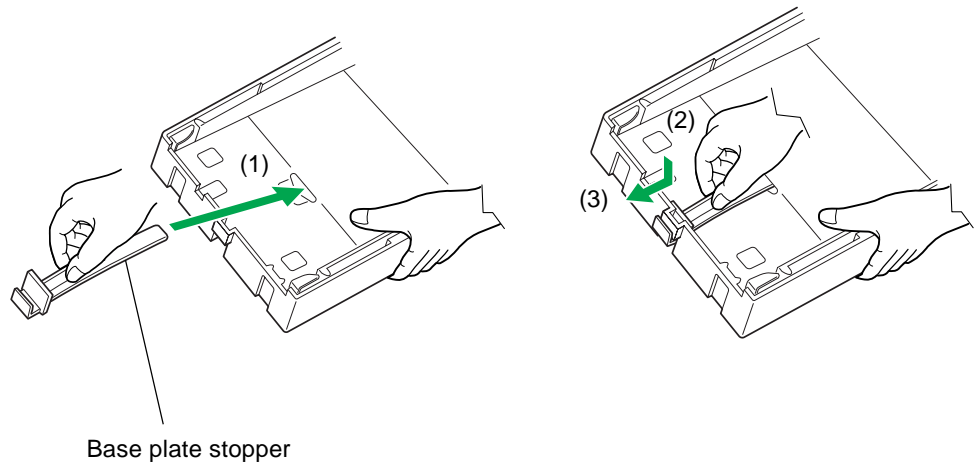

- 4 Reinsert the media cassette into the printer; use adhesive tape to secure the cassette to the printer.
- 5 If you have other media cassettes, repack them for shipping or storage in their original shipping boxes.
- 6 (1) Open the printer's front cover.
(2) Loosen the two thumbscrews by turning them counterclockwise.
(3) Turn the lower green lever 180° counterclockwise.

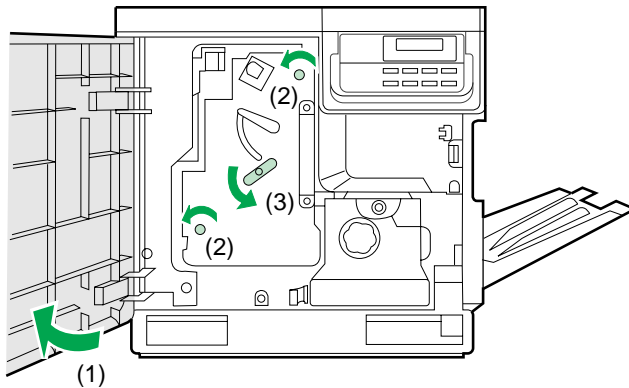

- 7 (1) Grasping the front green handle, slide the unit out until it catches.
(2) Lift up the green handle on the left. Pull the imaging unit out of the printer.

Important:

Do not touch the green surface (the right side) or the black belt (the under side). Finger prints may affect the print quality.

Safety Caution:

The imaging unit weighs approximately 6.5 kg (14 lbs.). Always use the handles when lifting it.

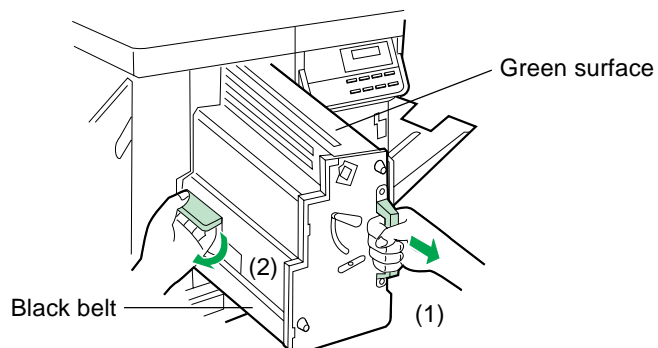

Care and Maintenance

- 8** Wrap the imaging unit with a protective black plastic sheet.

Caution:

Do not expose the imaging unit to light for more than 45 seconds to avoid damage.

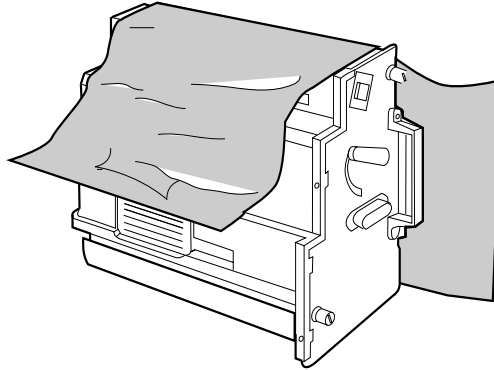

- 9** On the imaging unit, turn the upper lever 90° counterclockwise; this is necessary to protect the imaging unit during shipment.

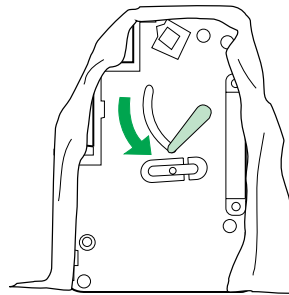

- 10** Insert the imaging unit into the packaging carton.

- 11** (1) Open the left side cover.
(2) Using the green handles, slide the paper feeder out.

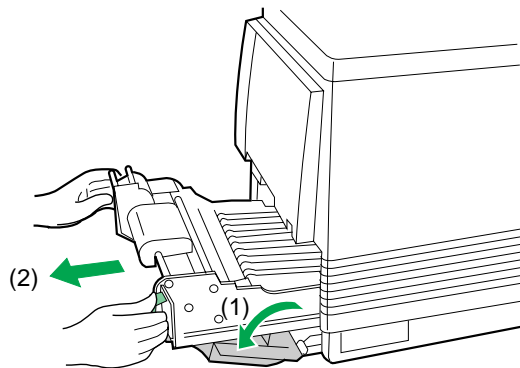

- 12** (1) Push in on green tabs to unlock the cover.
(2) Raise the cover until it catches in the open position.

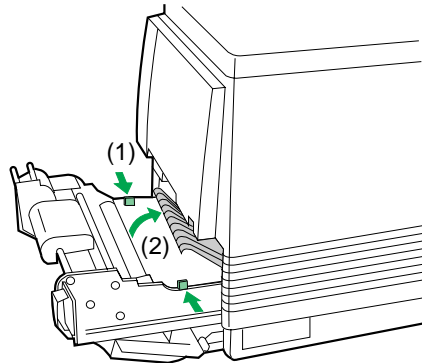

- 13** (1) Rotate the transfer unit's green handles up.
(2) Lift out the transfer unit.

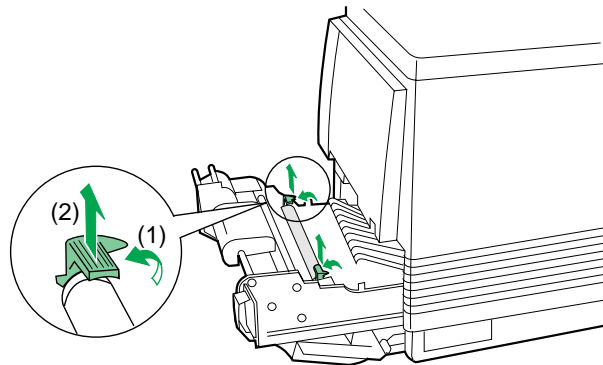

- 14** Place the transfer unit on newspaper or drop cloth. Rotate the handles down and wrap the transfer unit with a piece of paper and adhesive tape.

Note:

Do not touch or bump the roller. It can damage the roller.

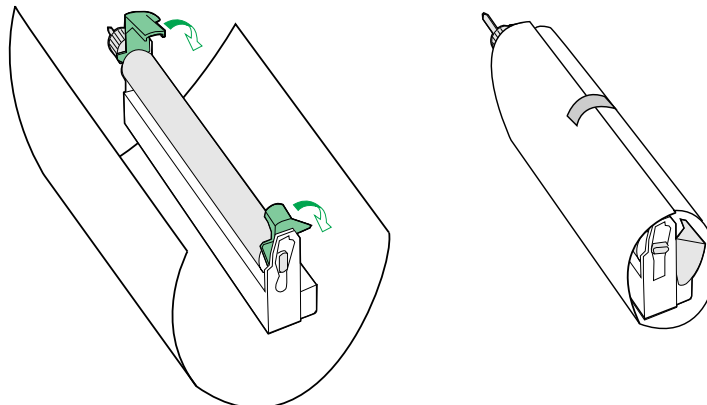

Care and Maintenance

- 15** Install the plastic cover and insert the transfer unit into a plastic bag and seal the end tightly. Install the transfer unit into the packaging.

Note:

Use the plastic cover that is originally fitted with a new TR-81 transfer unit.

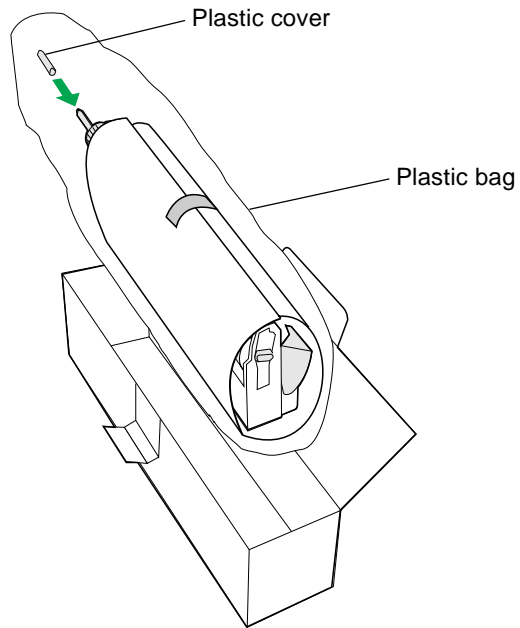

- 16** Packing the toner developers:

- (1) Open the right side cover.
- (2) Remove the toner developer.

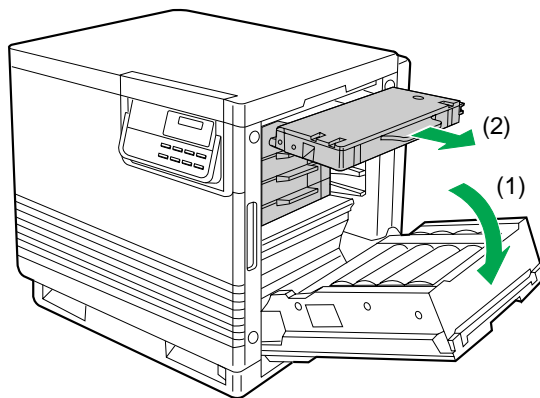

Caution:

To avoid possible toner spillage, do not tilt the toner developer.

(3) Replace the shipping cover.

(4) Secure the shipping cover with adhesive tape.

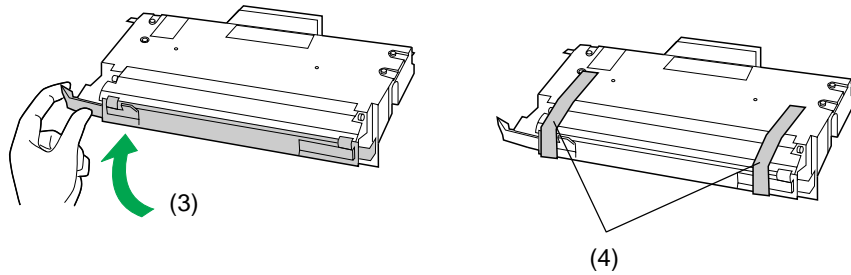

(5) Insert each toner developer into a plastic bag and seal the end of the bag tightly.

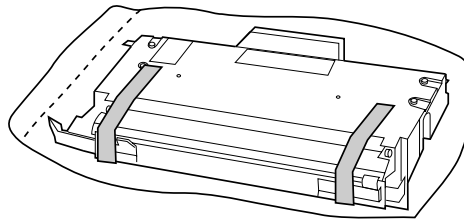

(6) Repeat instructions (2) to (5) for each toner developer.

17 Wipe off any loose toner in and around the printer.

Note:

If a toner vacuum is available, use it for cleaning spilled toner. Do not use a standard office vacuum; the toner will not be retained by typical vacuum dust collectors.

Care and Maintenance

- 18** (1) Raise the output tray and secure it to the printer with adhesive tape.
- (2) Secure the front cover, the multi-purpose tray and the left side cover to the printer with adhesive tape.

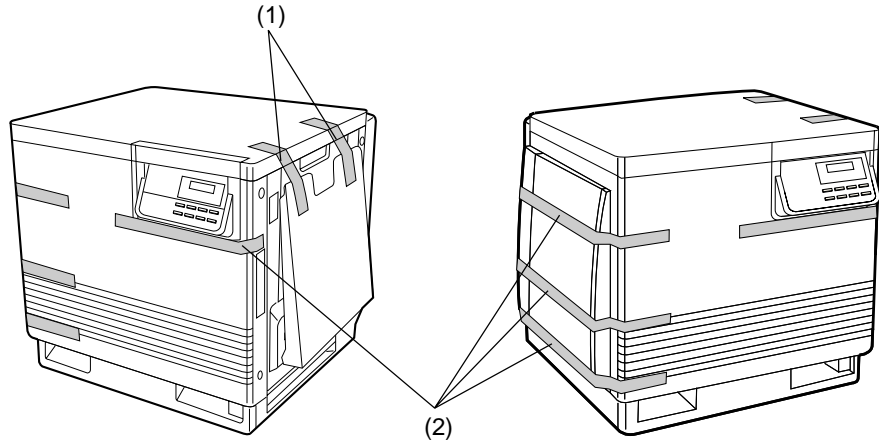

If you don't have an option Paper Feeder, go to step 20.

19 If you have an option Paper Feeder:

- (1) Lift the printer up and away from the Paper Feeder.

Safety Caution:

The printer weighs approximately 46.6 kg (103 lbs.) and the Paper Feeder weighs approximately 14.4 kg (32 lbs.). Observe standard precautions for lifting heavy objects.

- (2) Repack the Paper Feeder in its original shipping box.

20 Repack any other accessories in the original shipping box. Refer to the diagram on the next page.

Care and Maintenance

- 21** Repack the printer in the original shipping box. Refer to the diagram below. Make sure that you keep the printer upright and level when moving.

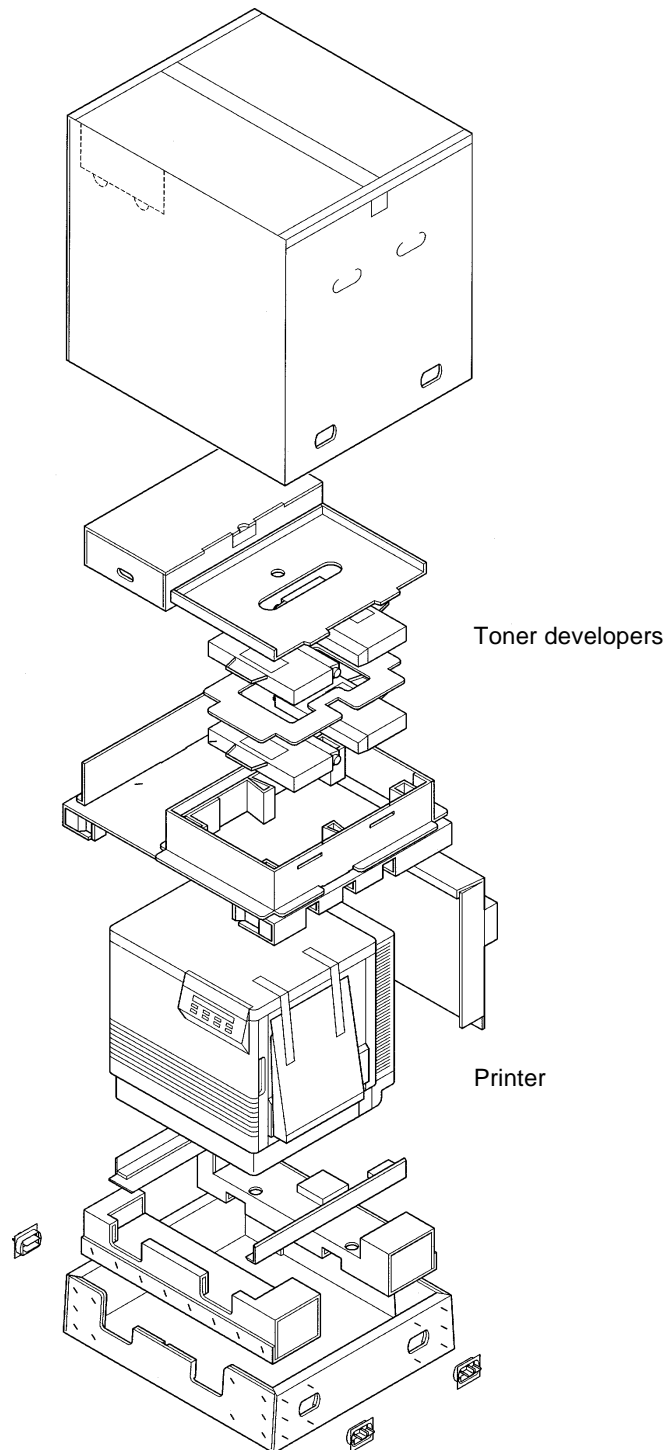

Specifications

Printer

Power source

Refer to the nameplate on the rear of the unit.

Temperature

Operating: 10°C to 32.5°C (50°F to 90.5°F)

Recommended Operating: 16°C to 27°C (60°F to 81°F)

Storage: 0°C to 40°C (32°F to 104°F)

Humidity

Operating: 15% to 80% RH

Recommended Operating: 36% to 63% RH

Storage: 10% to 80% RH

Warm-up time

Less than 330 seconds (22°C/50%)

Power consumption

Max. 920 W

During sleeping less than 45 W

Mass (Weight) less than standard unit with all consumables

(without optional Paper Feeder)

51Kg (112 lbs)

Dimensions of standard unit (Without Paper Feeder)

Height: 462 mm (18.2")

Depth: 493 mm (19.4")

Width: 510 mm (20.1") [784 mm (30.9") with the output tray]

Noise level

53 dB(A) [Printing mode]

47 dB(A) [Standby mode]

Printing method

Semiconductor Laser

Paper output

Up to 500 sheets [75 g/m² (20 lbs.)]

Resolution

600 × 600 dpi

1200 × 1200 dpi (KPD L)

Main Memory

Standard 48 MB, expandable up to 112 MB (SIMM slots × 3)

Maximum printing speed

The print speeds listed in the following table represent the time the printer produces multiple prints on various media and resolution (**Continuous throughput rate**).

Continuous Print Speed (ppm)

Media Type		Plain Paper				Labels, Coated Card stock 2nd side*		Transparency	
		A4/Letter		Legal					
		Colour	Mono	Colour	Mono	Colour	Mono	Colour	Mono
Simplex	600 × 600 dpi	4	16	2	8	2	8	2	8
	1200 × 1200 dpi	2	8	1	4	2	8	-	-
Duplex	600 × 600 dpi	2	4	1	2	-	-	-	-
	1200 × 1200 dpi	1	2	0.5	1	-	-	-	-

The figures in **Colour** above depend on using the four colour mode (See **Colour mode** on page 44.).

Interface

Standard: Bi-directional Parallel, serial (8-pin DIN)

Option: Slot for the network interface card

Altitude

Operating: 0 to 2,500 m (8,000 ft.)

Storage: 0 to 4,000 m (13,125 ft.)

Media

Media Sizes

Medium	Size	Dimensions
Paper	Letter	8.5" × 11"
	A4	210 mm × 297 mm
	JIS B5	182 mm × 257 mm
	ISO B5	176 mm × 250 mm
	Legal	8.5" × 14"
	Executive	7- ¹ / ₄ × 10- ¹ / ₂
Transparency	Letter	8.5" × 11"
	A4	210 mm × 297 mm

Note:

Please store your paper according to the recommendations of the manufacturer.

Margins and Print Area

When the image is printed on the media, the image (print area) is a bit smaller than the media size. You may need to adjust the page margins in the application software to match the print area.

The following table and illustrations show the page sizes, the largest print areas, and the margins for the media sizes in KPD L emulation.

Media	Paper size		Edge limits (A) (dot)		Printable area (B) (dot)
	cm/inch	Points	Horizontal	Vertical	
A4	21.0 × 29.7 cm	595 × 842	112	120	4736 × 6784
B5	18.2 × 25.7 cm	516 × 729	174	97	3950 × 5875
ISO B5	17.6 × 25.0 cm	499 × 708	99	102	3958 × 5700
Legal	8.5 × 14 inches	612 × 1008	86	136	4928 × 8128
Letter	8.5 × 11 inches	612 × 792	86	132	4928 × 6336
Executive	7.25 × 10.5 inches	522 × 756	100	100	4150 × 6100

(600 dpi)

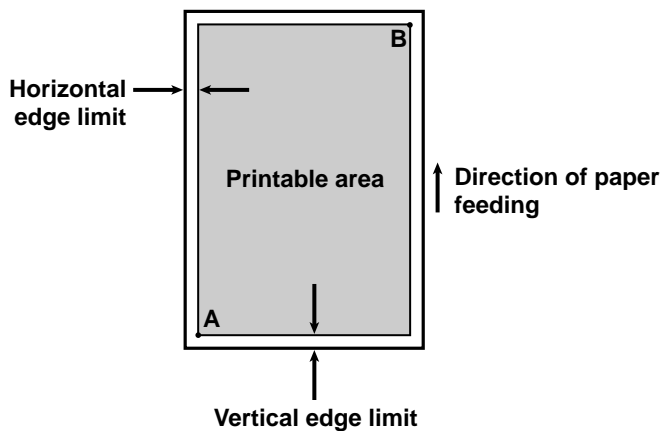

■ Paper Weight

The printer is designed to work well with most types of paper. However, differences in paper may have significant effects on the quality of the print or the reliability of paper handling.

It is strongly recommended that you always test paper before purchasing it to make sure it provides desirable performance.

Media cassette*	One-sided printing	Monochrome	60 to 105 g/m ² (16 to 28 lbs.)
		Colour	75 to 105 g/m ² (20 to 28 lbs.)
Duplex Unit	Two-sided printing	Monochrome	75 to 90 g/m ² (20 to 24 lbs.)
		Colour	75 to 90 g/m ² (20 to 24 lbs.)
Multi-purpose tray	One-sided printing	Monochrome	75 to 165 g/m ² (20 to 44 lbs.)
		Colour	75 to 165 g/m ² (20 to 44 lbs.)

- Recommended paper (for optimum performance):

LETTER/LEGAL: Hammermill LASERPRINT 90 g/m² (24 lbs.)

A4: NEUSIEDLER COLOR COPY 90 g/m²

* We do not recommend the use of 105 g/m² (28 lbs.) paper in areas of high or low humidity and temperature since paper feed problems may be experienced.

■ Types of Paper to Avoid

- Extremely smooth or shiny paper or paper that is highly textured
- Letterhead imprinted with low temperature or thermography. These materials may transfer onto the fusing roller and cause damage. Any pre-printed paper should use inks compatible with 200°C (392°F) for 0.1 second.
- Damaged or wrinkled paper, or paper with irregularities such as tabs, staples, etc.
- Multipart forms or carbonless paper
- Paper with a 25% or more cotton and/or fibre content
- Ink jet paper (It may transfer onto the fuser roller and cause damage.)

■ Transparencies and Labels

You may also print on transparencies and labels that are made for the printer. The following work satisfactorily.

OHP transparency	3M CG3700, 3M CG3710
Labels	AVERY 5163, AVERY 5164, AVERY 5165 Avery L7163, Avery L7165, Avery L7166, Avery L7167 Avery L7168, Avery L7169

Using OHP Film

When printing on OHP film it is extremely important that the correct side of the film be facing up when it is loaded into the printer. Failure to load the film correctly may result in jams or damage to the printer.

Note:

No precaution is necessary when using 3M CG3700 film, as this film can be printed on either side and fed in any direction.

- When loading OHP film into the multi-purpose tray

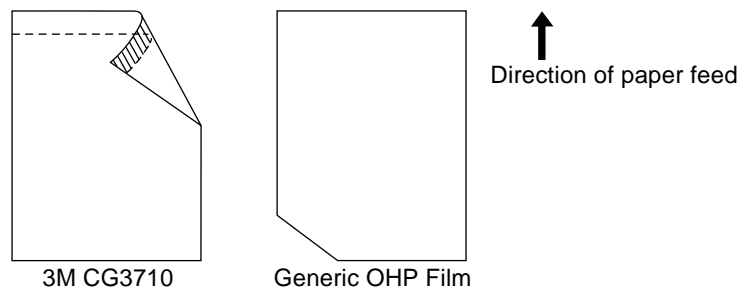

When using OHP film that has an adhesive paper strip (3M CG3710), make sure that the paper strip is on the leading edge and that the paper strip is facing DOWN.

When using OHP film that has a notched corner, make sure that the notched corner is on the trailing edge and that the notched corner is on the left.

- When loading OHP film into the cassette

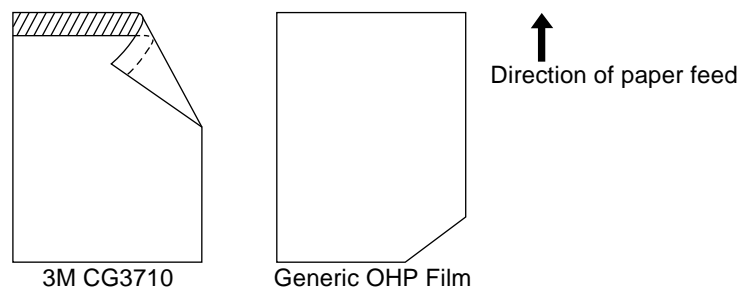

When using OHP film that has an adhesive paper strip (3M CG3710), make sure that the paper strip is on the leading edge and that the paper strip is facing UP.

When using OHP film that has a notched corner, make sure that the notched corner is on the trailing edge and that the notched corner is on the right.

- Re-using transparencies that have been fed through the printer once (for example, after jams or if the transparency is ejected without being printed) can reduce the life of the consumables and paper path components.
- With any label stock, the labels must completely cover the backing material.

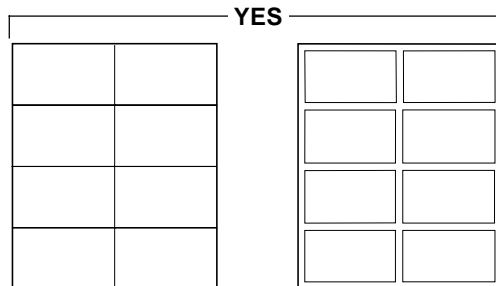

Labels cover the entire backing material

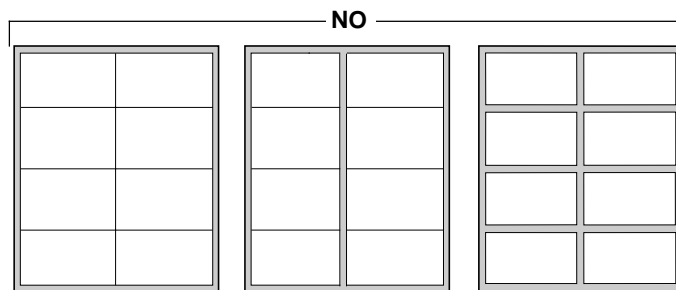

The backing material is exposed.

Software

Windows Version

- Windows 3.1, Windows 95, Windows98, Windows NT 3.51/4.0

KPDL Printer Driver

Colour Management: ICM

System Requirement

CPU:	More than Pentium (133 MHz or faster CPU is recommended.)
Operating System:	Windows 3.1, Windows 95, Windows98, Windows NT 3.51/4.0
Memory:	16 MB or more (More than 32 MB is recommended.)
Free disk space:	100 MB or more
Virtual memory:	16 MB or more (More than 32 MB is recommended.)
Display:	Video card that display more than 256 colours. (A video card that can display more than 32,000 colours is recommended.)
Drive:	CD-ROM drive

Bi-directional Parallel Interface

The bi-directional parallel interface is based on the IEEE1284 standard.

If your computer has a bi-directional parallel port, the printer driver and printer can take advantage of faster data transfer.

Specifications

Connector Type	IEEE1284 type connector
Cable	Use a shielded cable 2 m (6.6 ft.) or less in length.

Pin configuration

Signal Pin	Return side pin	Signal
1	19	nStrobe
2	20	Data 1
3	21	Data 2
4	22	Data 3
5	23	Data 4
6	24	Data 5
7	25	Data 6
8	26	Data 7
9	27	Data 8
10	28	nAck

Signal Pin	Return side pin	Signal
11	29	Busy
12	30	PError
13	31	Select
14	32	nAutoFd
18	-	+5V(Peripheral)
31	-	nInit
32	-	nFault
35	-	+5V(Host)
36	-	nSelection

Parallel Interface connector (printer side)

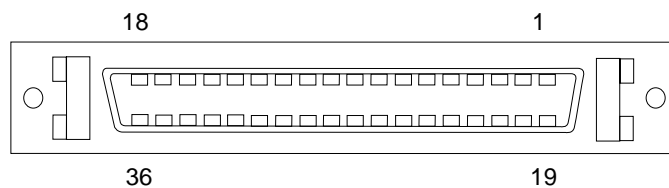

Notes:

- “Return” denotes the return side wire of a twisted pair cable and is connected to signal ground.
- Be sure to use only a shielded cable. The printer will not operate properly if any of the pins are not connected.

A

AC inlet	7, 24
ATTENTION indicator	8, 10
Audio alarm	50
Auto cassette mode	47

C

Calibration Page	30-33
CANCEL key	8, 11
Cassette feed indicator	8, 10
Caution Labels	xi
Cautions	ix, xi, 1
CD-ROM	2, 6, 27-29
Cleaning pad	70
Cleaning the duplex unit	65
Cleaning the optional feeder	65
Cleaning the printer	64
Cleaning the sensor	66
Clearing a jam	71
Colour calibration	45
Colour calibration card	32
Colour calibration page	32
Colour Density	30
Colour matching	44
Colour mode	44
Connecting	
Printer to computer	23
CONTINUE/< key	8, 11
Control panel	8
Copy Indicator	9
CR action	49

D

DATA indicator	8, 10
Declaration of Conformity (U.S.A.)	iv
Duplex indicator	10

E

Emulation	39
ENERGY STAR	vi
ENTER/STATUS key	8, 11
Error Messages	93
Printer Panel	93
EXIT/MODE key	8, 11

F

Face-down indicator	10
Features	3
FEED/- key	8, 11
Font	39
Font manager	39
FOR USERS IN U.K.	xii
For your safety	ix

FORM FEED/> key	8, 11
Formfeed timeout time	48
Front cover	7, 12, 74, 76, 77
Fuser	7, 70, 74-77

H

Hard Disk Error Codes	100
Hard disk option	25
Harddisk	43

I

Imaging unit	7, 12, 66-68, 69
Installing the driver software	27
Installing the toner developers	14
Interface	4, 38
Bi-directional Parallel Interface	116
Cable	24-25, 116
Connector	24-25
Interface Indicator	9

J

Jam at A	72, 81, 84
Jam at B	73
Jam at C	74-77
Jam at D	78-79, 82-83
Jam at E	80
Jam at F	81
Jam at G	82
Jam at H	84
Jam clearing	71

K

KPDL Error Codes	100
Kyocera Digital Library CD-ROM	27-29

L

Left side cover	7, 19, 72
LF action	49
Life counters	45
Limit mark	18, 21
List of resident fonts	48
Loading labels	22
Loading media in the multi-purpose tray	19
Loading paper	20-21
Loading paper or transparencies in the Media Casse 16	

M

Main charger	70
Margins and print area	19
Media cassette	16-18, 72, 84
Media problems	91
Media sizes	111

Index

Memory Card	57
Memory card	43, 44
Memory Card Error Codes	61
Menus	37, 38, 47
Message Display	8
Message language	47
Minimum space requirements	5
Mode selection	34
Moving the unit	x
MP tray mode	46
Multi-purpose (MP) tray	7, 19
Multi-purpose feed indicator	8, 10

N

Number of copies	39
------------------------	----

O

Oil supply roll	70, 75, 76
ON LINE indicator	8
ON LINE key	8, 11
Option ROM	43
Output tray	13, 79, 80

P

Page orientation	43
Paper	
Feeder	64, 65, 73
Loading	20
trays	16
Paper handling mode	46
Paper Size Indicator	9
Paper Weight	113
Paper-pick	64, 65
Parallel interface	116
Parallel interface cable	24
Parallel interface connector	24
Part names	7
Control panel overview	8
Front side view	7
PC 4	
Plug and Play	28
Power cord	24
Power On	25
Power source	5
Power switch	7
Preparing the imaging unit	12
Print HEX-DUMP	48
Print quality problems	92
Printer driver	27
Printer driver for Windows 3.1	27, 28
Printer driver for Windows 95/Windows 98	28
Printer panel message	93
Printer Reset	49
Printing a status page	26

Problems with image size and position	91
---	----

R

RAM DISK	51
RAM DISK mode	43
Repacking	101
Resolution	49
Resolution Indicator	9
Resource Protection	62
Resource protection	50
Right side cover	7, 14, 78

S

Serial interface	25
Service	50
Setting media thickness	19
Setting the colour density	30
Setting the Sleep Timer	62
Setting up the Multi-purpose (MP) tray	20
Sleep timer	48
Software specifications	115
Specifications	110
Interface	116
Media	111, 115
Printer	110
STACK indicator	8
STACK/+ key	8, 11
Static electricity damage	2
Status Page	26
System	
Connecting	23
Requirements	4

T

Thickness	
Media	19
Switch	19
Toner developers	69
Toner indicator	8, 10
Trademarks	i
Transfer unit	70
Transparencies and labels	114
Transparency	16, 114
Troubleshooting	85
Two-sided printing	113
Types of paper to avoid	113

U

Unpacking	6
Upper green lever	12
User replaceable components	69

V

Virtual Mail Box (VMB)..... 52

W

Warnings ix

Windows 3.1 4, 27, 28, 115

Windows 95 4, 115